

ΛΕΙΤΟΥΡΓΙΑ – FUNZIONAMENTO UTILIZAÇÃO – FUNCIONAMIENTO



3X9059

Αναθ. Β
Rev. Β
Rév. Β

190ES™

232900 – 232909

3000 psi (207 bar, 20,7 MPa) Μέγιστη Πίεση Εργασίας
Pressione massima d'esercizio 3000 psi (207 bar, 20,7 MPa)
Pressão máxima de trabalho de 3000 psi (207 bar, 20,7 MPa)
Presión máxima de funcionamiento de 3000 psi (207 bar, 20,7 MPa)

Όλα τα μοντέλα δεν είναι διαθέσιμα σε όλες τις χώρες
 Non tutti i modelli sono in vendita in tutti i paesi
 Nem todos os modelos se encontram disponíveis em todos os países
 Hay modelos que no se distribuyen en todos los países

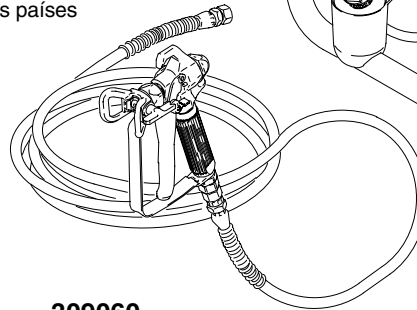
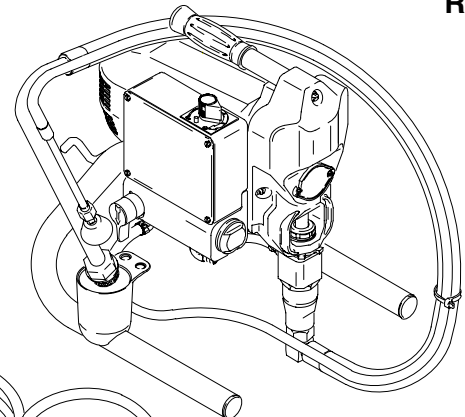

232900

T10051

Σχετικά Εγχειρίδια
 Manuali pertinenti
 Manuais associados
 Manuales relacionados



..... 309063

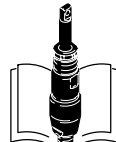

..... 309060



..... 309064



..... 309061



..... 308644



..... 309065

ΟΔΗΓΙΕΣ	ISTRUZIONI
<p>ΔΙΑΒΑΣΤΕ ΟΛΕΣ ΤΙΣ ΟΔΗΓΙΕΣ ΚΑΙ ΤΙΣ ΠΡΟΕΙΔΟΠΟΙΗΣΕΙΣ ΠΡΙΝ ΤΗ ΣΥΝΑΡΜΟΛΟΓΗΣΗ ΚΑΙ ΛΕΙΤΟΥΡΓΙΑ ΤΗΣ ΠΑΡΟΥΣΑΣ ΜΟΝΑΔΑΣ.</p> <p>Χρειάζεστε:</p> <ul style="list-style-type: none"> • Δύο ρυθμιζόμενα γαλλικά κλειδιά • Δύο μεταλλικά δοχεία χωρητικότητας 19 λίτρα • Συμβατά υγρά καθαρισμού <p>   </p> <p>Με βάση το λάδι Λάτεξ</p> <p>Στολή:</p> <ul style="list-style-type: none"> • Αναπνευστήρας • Προστατευτικά γυαλιά <p> Ισχύς: γειωμένη έξοδος Ιαπωνία: 100V, 15A Ηνωμένο Βασίλειο: 110V, 15A Βόρεια/Λατινική Αμερ: 120V, 15A Ευρώπη/Νότια Αμερ: 230V, 10A Αυστραλία/Ασία: 240V, 10A • Γειωμένο καλώδιο προέκτασης 12 AWG, (1,5 mm²) έως και 300 πόδια (100 M) </p>	<p>LEGGERE TUTTE LE ISTRUZIONI E LE AVVERTENZE PRIMA DI IMPOSTARE O FAR FUNZIONARE QUESTA UNITÀ.</p> <p>Occorre il seguente materiale:</p> <ul style="list-style-type: none"> • Due viti regolabili • due secchi metallici da 19 litri • Fluidi per la pulizia compatibili <p>   </p> <p>A base oleosa Lattice</p> <p>Indumenti:</p> <ul style="list-style-type: none"> • Respiratore • Occhiali di protezione <p> Alimentazione: uscita con messa a terra Giappone: 100 V, 15 A Regno Unito: 110 V, 15 A Nord/America Latina: 120 V, 15 A Europa/Sud America: 230 V, 10 A Australia/Asia: 240 V, 10 A • 12 AWG, (1,5 mm²) con messa a terra prolunga fino a 100 metri </p>
INSTRUÇÕES	INSTRUCCIONES
<p>LEIA TODAS AS INSTRUÇÕES E ADVERTÊNCIAS ANTES DE MONTAR OU UTILIZAR ESTA UNIDADE.</p> <p>Você precisa de:</p> <ul style="list-style-type: none"> • Duas chaves inglesas • Dois baldes metálicos de 19 litros • Líquidos de limpeza compatíveis <p>   </p> <p>À base de óleo Látex</p> <p>Vestuário:</p> <ul style="list-style-type: none"> • Máscara de respiração • Óculos protectores <p> Alimentação: tomada ligada a terra Japão: 100V, 15A Reino Unido: 110V, 15A Am. do Norte/Latina: 120V, 15A Europa/Am. do Sul: 230V, 10A Austrália/Ásia: 240V, 10A • Fio de extensão 12 AWG, (1,5 mm²) com ligação terra até 100 M. </p>	<p>LEA TODAS LAS INSTRUCCIONES Y ADVERTENCIAS ANTES DE PONER EN MARCHA O DE HACER FUNCIONAR ESTA UNIDAD.</p> <p>Necesitará:</p> <ul style="list-style-type: none"> • Dos llaves inglesas • Dos cubos de metal de 19 litros • Fluidos de limpieza compatibles <p>   </p> <p>Base de aceite Látex</p> <p>Ropas:</p> <ul style="list-style-type: none"> • Respirador • Gafas de seguridad <p> Potencia: toma eléctrica conectada a tierra Japón: 100V, 15A Reino Unido: 110V, 15A Norteam./Am. Latina: 120V, 15A Europa/Sudam.: 230V, 10A Australia/Asia: 240V, 10A • 12 AWG, (1,5 mm²) cable de extensión de hasta 100 m (300 pies) conectado a tierra </p>

**GRACO N.V.; Industrieterrein — Oude Bunders;
 Slakweidestraat 31, 3630 Maasmechelen, Belgium
 Tel.: 32 89 770 700 – Fax: 32 89 770 777**

©COPYRIGHT 1999, GRACO INC.



ΠΡΟΕΙΔΟΠΟΙΗΣΗ

Κίνδυνος ανάφλεξης και έκρηξης: Οι αναθυμιάσεις από το χρώμα και το διαλύτη ενδέχεται να προκαλέσουν ανάφλεξη ή έκρηξη.

Για να αποφύγετε τυχόν ανάφλεξη και έκρηξη:

- Χρησιμοποιείτε μόνο σε χώρους με άριστο αερισμό.
- Εξουδετερώνετε όλες τις πιθανές πηγές ανάφλεξης, όπως λυχνίες καθοδήγησης, τσιγάρα και στατικά τόξα από πλαστικά υφάσματα. Μη συνδέετε ή αποσυνδέετε τα καλώδια τροφοδότησης και μην ανάβετε ή σβήνετε τα φώτα στο χώρο της βαφής.
- Γειώνετε το μηχάνημα βαφής, το αντικείμενο που βάφετε, τα δοχεία του χρώματος και του διαλύτη.
- Όταν τραβάτε τη σκανδάλη σηματοδοτώντας το δοχείο κρατάτε το πιστόλι σταθερά στο πλάι του γεωμενίου δοχείου.
- Χρησιμοποιείτε μόνο αγώγιμο σωλήνα βαφής χρώματος χωρίς αέρα.
- Μη χρησιμοποιείτε 1,1,1-τριχλωροεθάνιο, χλωριούχο μεθυλένιο, άλλους διαλύτες αλογονωμένου υδρογονάνθρακα ή ρευστά που περιέχουν τέτοιους διαλύτες σε υπό πίεση εξοπλισμό αλουμινίου. Σε αντίθετη περίπτωση ενδέχεται να προκληθεί χημική αντίδραση, με πιθανότητα έκρηξης.

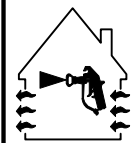

PERICOLO

Pericolo di incendio e di esplosione: Il solvente ed i fumi di vernici possono esplodere o prendere fuoco.

Per aiutare a prevenire un incendio o un'esplosione:

- **Utilizzare solo in aree estremamente ben ventilate.**
- Eliminare tutte le fonti di incendio; come le fiamme pilota, le sigarette e gli archi statici dalle coperture in plastica. Non collegare o scollegare i cavi di alimentazione o accendere o spegnere luci nell'area di spruzzatura.
- Collegare a terra lo spruzzatore, l'oggetto che viene spruzzato ed i secchi di vernice e di solvente.
- Tenere ferma la pistola su un lato di un secchio collegato a terra quando si attiva nel secchio.
- Utilizzare solo flessibili conduttivi per spruzzatura airless.
- Nelle pompe di alluminio pressurizzate non utilizzare mai 1,1,1-tricloroetano, cloruro di metilene, altri solventi a base di idrocarburi alogenati o fluidi contenenti tali solventi. Il loro utilizzo può provocare una reazione chimica con una possibile esplosione.

Κίνδυνος έγχυσης ρευστού και κίνδυνος υψηλής πίεσης: Ψεκασμός ή διαρροές με υψηλή πίεση ενδέχεται να προκαλέσουν έγχυση ρευστού στον οργανισμό.

Για να αποφύγετε την έγχυση, φροντίστε πάντα:

- Να ασφαλίσετε την ασφάλεια της σκανδάλης όταν δεν χρησιμοποιείτε το μηχάνημα βαφής.
- Να αποφεύγετε την επαφή με το μπέκ και τις διαρροές.
- Να μην ψεκάτε ποτέ χωρίς προφυλακτήρα για το μπέκ.
- Να προβαίνετε σε ΕΚΤΟΝΩΣΗ ΤΗΣ ΠΙΕΣΗΣ όταν διακόπτετε την βαφή ή αρχίζετε συντήρηση του μηχανήματος βαφής.
- Να μην χρησιμοποιείτε εξαρτήματα που έχουν ρυθμιστεί για πίεση χαμηλότερη από τη Μέγιστη Πίεση Εργασίας του μηχανήματος βαφής.
- Να μην επιτρέπετε ποτέ τη χρήση της παρούσας μονάδας από παιδιά.

Σε περίπτωση που το υψηλής πίεσης ρευστό διαπεράσει το δέρμα σας, η πληγή μπορεί να φαίνεται ως "ένα απλό κόψιμο". Πρόκειται όμως για σοβαρό τραυματισμό! Ζητήστε αμέσως ιατρική βοήθεια.

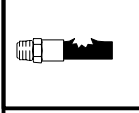

Pericolo da iniezione di fluido ed alta pressione: Spruzzi o perdite ad alta pressione possono iniettare fluido nel corpo.

Per prevenire le iniezioni di fluido, sempre:

- Innescare sempre il gancio di sicurezza quando non si spruzza.
- Tenersi lontano dall'ugello e dalle perdite.
- Non spruzzare mai senza la protezione dell'ugello.
- **SCARICARE LA PRESSIONE** se si arresta la spruzzatura o si eseguono interventi di manutenzione sullo spruzzatore.
- Non utilizzare componenti con una pressione inferiore alla *massima pressione di esercizio del sistema*.
- Non consentire ai bambini di utilizzare questa unità.

Se fluido ad alta pressione ferisce la pelle, la lesione può sembrare un "semplice taglio". Ma è una lesione grave. Richiedere assistenza medica immediata.



ADVERTÊNCIA

Perigo de incêndio e explosão: os solventes e os vapores da tinta poderão explodir ou incendiar.

Para ajudar a evitar incêndio e explosão:

- **Utilize unicamente em áreas extremamente bem ventiladas.**
- Elimine todas as fontes de ignição, tais como luzes piloto, cigarros e arcos estáticos de plásticos de protecção. Não ligue nem desligue os cabos de alimentação nem as luzes numa área de pulverização.
- Ponha em contacto com a terra o equipamento, o objecto a ser pintado e os baldes de tinta e de solventes.
- Segure a pistola firmemente apoiando-a na parede do balde em contacto com a terra, quando estiver a descarregar para dentro do mesmo.
- Utilize apenas tubos flexíveis condutores para pintura a alta pressão.
- Não utilize 1,1,1-tricloroetano, cloreto de metileno, outros solventes de hidrocarbonetos halogenados ou líquidos contendo tais solventes em equipamento de alumínio pressurizado. Tal utilização poderá resultar numa reacção química, com possibilidade de explosão.

Perigo de injeção de líquidos e de alta pressão: a pulverização ou fugas a alta pressão podem injectar líquido na pele humana.

Para evitar a injeção de líquido, faça sempre o seguinte:

- Engate o trinco de segurança do gatilho quando não estiver a pulverizar.
- Mantenha-se afastado do bico e de eventuais fugas.
- Nunca pulverize sem protecção no bico.
- **ALIVIE A PRESSÃO** se parar de pintar e antes de iniciar a manutenção do equipamento.
- Não utilize componentes com uma pressão de serviço inferior à da *pressão máxima de trabalho* do equipamento.
- Nunca permita que crianças utilizem esta unidade.

Se o líquido a alta pressão penetrar na pele, o ferimento poderá parecer "simplesmente um corte". Mas é um ferimento grave! Procure imediatamente assistência médica.

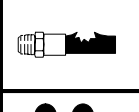
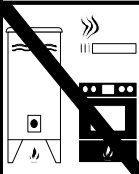

ADVERTENCIA

Perigo de incendio y explosión: Los vapores de disolvente o de pintura pueden incendiarse o explotar.

Para ayudar a evitar que se produzca un incendio o una explosión:

- **Utilice únicamente en áreas extremadamente bien ventiladas.**
- Elimine toda fuente de ignición; como las luces piloto, los cigarrillos y los arcos estáticos procedentes de cubiertas de plástico. No enchufe ni desenchufe aparatos en las tomas de corrientes de la zona de pulverización.
- Conecte a tierra el pulverizador, el objeto que está pintando y los cubos de disolvente.
- Sujete firmemente la pistola contra el lado de un recipiente conectado a tierra mientras dispara la pistola hacia el interior del mismo.
- Utilice únicamente mangueras de pintura sin aire, conductoras eléctricamente.
- No utilice nunca 1,1,1-tricloroetano, cloruro de metileno, otros disolventes de hidrocarburo halogenado o fluidos que contengan tales disolventes en una bomba a presión de aluminio. El uso de estas sustancias puede provocar una seria reacción química con riesgos de explosión.

Perigo de inyección de fluido y de alta presión: La pulverización o las fugas a alta presión pueden inyectar fluido en el cuerpo.

Para ayudar a evitar la inyección, siempre:

- Enganche el seguro del gatillo cuando no esté pulverizando.
 - Manténgase alejado de la boquilla y de las fugas.
 - No pulverice sin una protección en la boquilla.
 - Siga el procedimiento de **DESCOMPRESIÓN** si deja de pulverizar o al comenzar la revisión del pulverizador.
 - No use componentes cuya presión nominal sea menor que la *presión máxima de funcionamiento del pulverizador*.
 - Nunca permita que los niños utilicen esta unidad.
- Si el fluido a alta presión penetra la piel,** la herida puede parecer "un simple corte". ¡Pero se trata de una herida grave! Consiga inmediatamente atención médica.

ΟΡΓΑΝΑ ΕΛΕΓΧΟΥ / CONTROLLI / CONTROLOS / CONTROLES

Διακόπτης On/Off / Interruttore On/Off /
Interrupor de ligar e desligar /
Interruptor On/Off

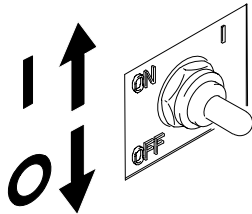

Ασφάλεια Σκανδάλης / Sicura del grilletto
Fecho do gatilho / Seguro del gatillo

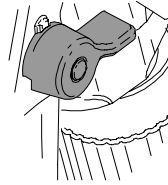

Μετρητής Πίεσης / Manometro
Manómetro / Manómetro

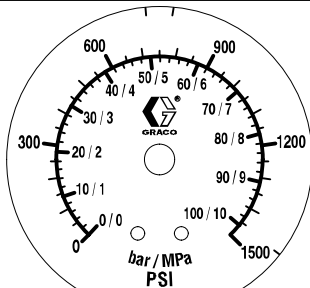

Δεν υπάρχει σε όλα τα μοντέλα / Non
disponibile in tutti i modelli / Não disponível
em todos os modelos / No está disponible
en todos los modelos

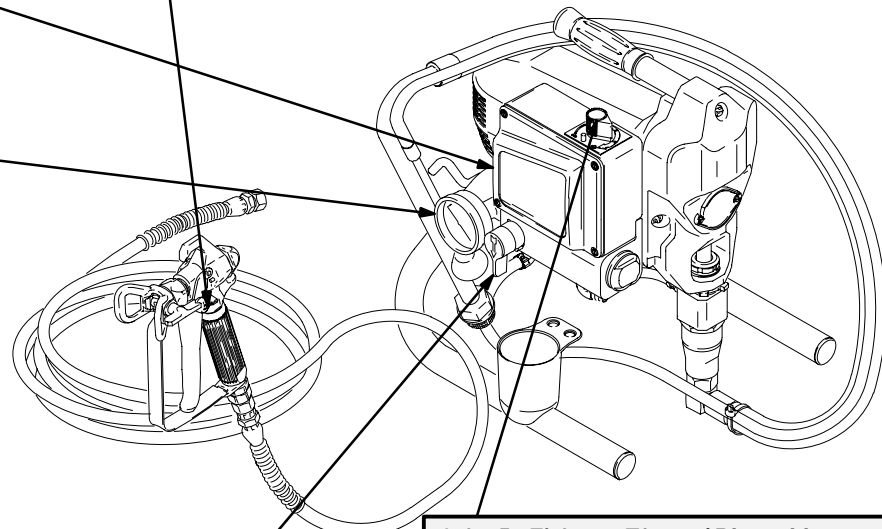

Βαλβίδα Αποστράγγισης / Valvola di scarico Válvula
de retorno / Válvula de drenaje

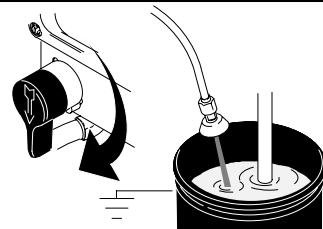
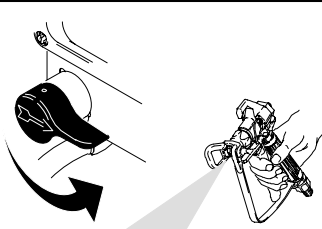

Διάταξη Ελέγχου Πίεσης / Dispositivo
di controllo di pressione / Regulador da
pressão / Control de presión



PSI/bar/MPa

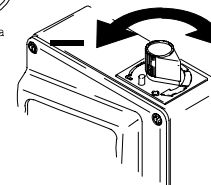

PSI/bar/MPa

ΕΚΤΟΝΩΣΗ ΠΙΕΣΗΣ / DECOMPRESSIONE DESCOMPRESSÃO / DESCOMPRESIÓN



Μετά το πέρας της βαφής
ακολουθήστε τα βήματα 1-5.

Seguire i passi da 1-5
quando si smette di
spruzzare.

Siga os passos de 1-5 quando parar
de pintar.

Cuando deje de pulverizar, siga los
pasos 1-5.

1

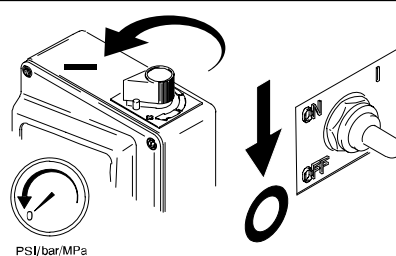

2

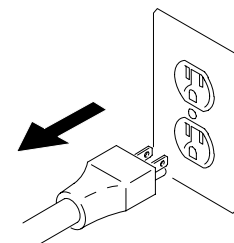

3

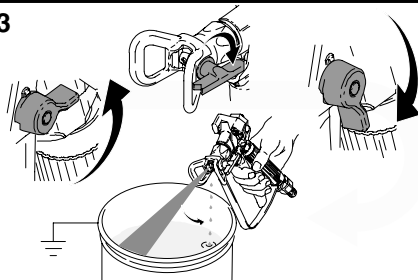

4



5

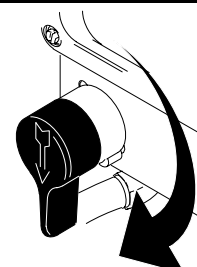

ΕΚΚΙΝΗΣΗ / AVVIAMENTO / ARRANQUE / PUESTA EN MARCHA

Ξεπλύνετε με ζεστό νερό και σαπουνάδα.
Lavare con acqua saponata tiepida.
Circule água, de preferência quente e com sabão.
Lave con agua jabonosa caliente.

Ξεπλύνετε με διαλυτή πετρελαίου.
Sciacquare con acqua ragia.
Finalmente, injecte diluente.
Lave con alcoholes minerales.

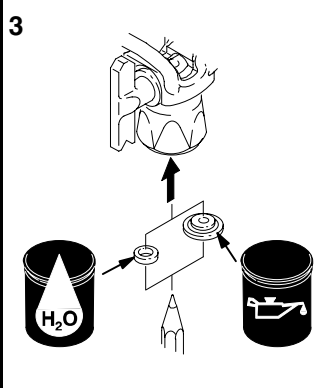
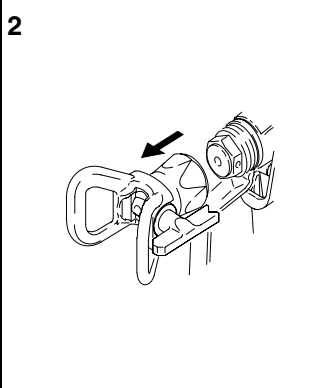
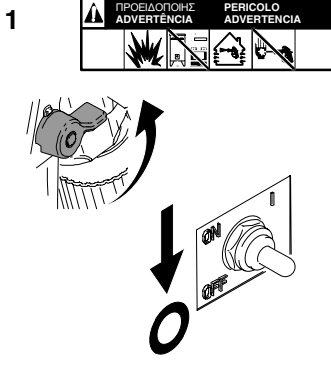

Ξέπλυμα / Lavare / Lavagem / Lavado 4→11

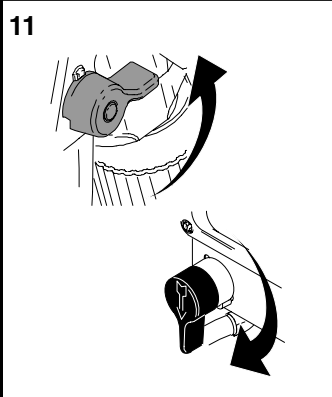
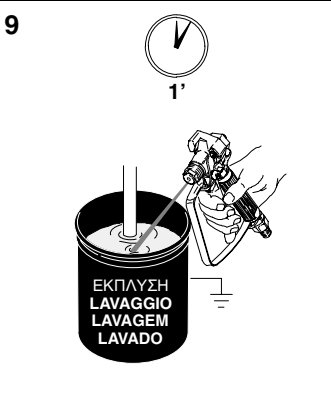
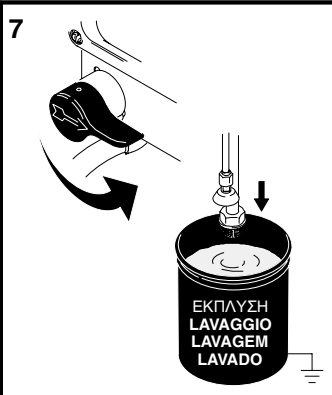
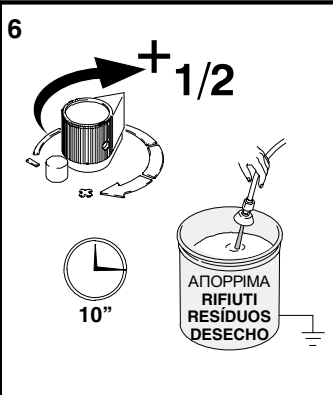
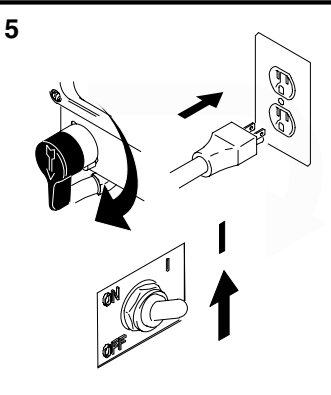

Προέγχιση / Adescare / Ferrar / Cebado 12→15

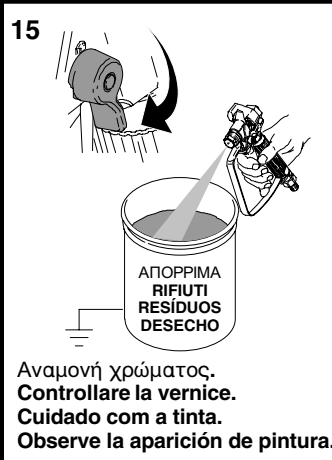
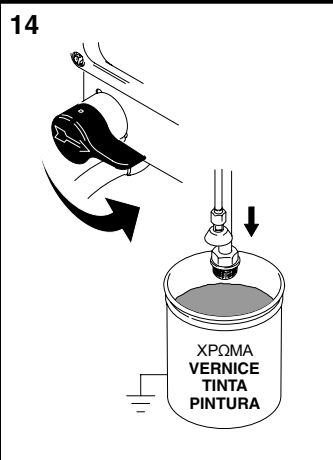
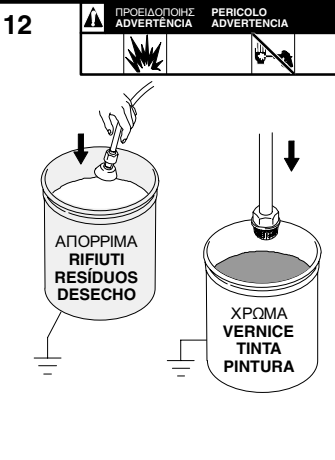

ΒΑΦΗ / SPRUZZATURA / PINTURA / PULVERIZACIÓN

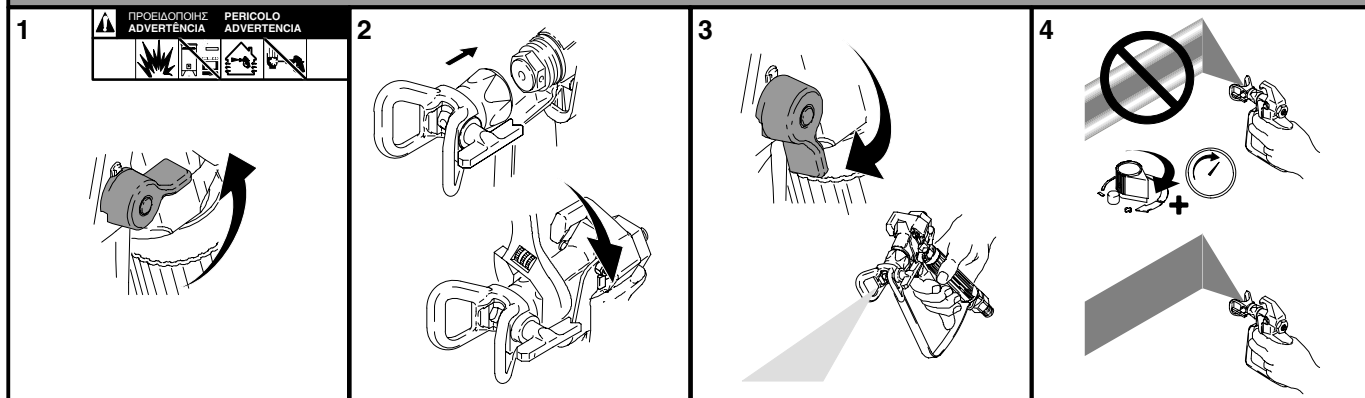



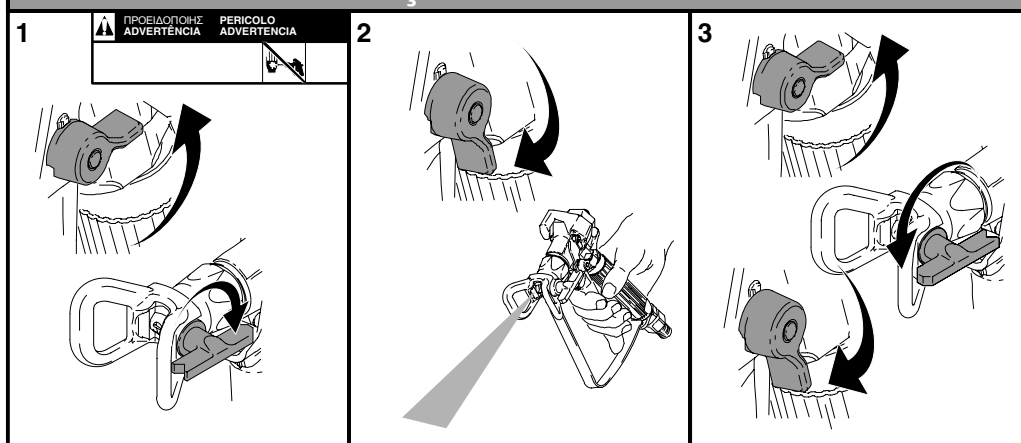

ΚΑΘΑΡΙΣΜΟΣ / PULIZIA DELLE OSTRUZIONI ELIMINAR A OBSTRUÇÃO / ELIMINAR OBSTRUCCIÓN

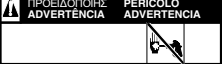
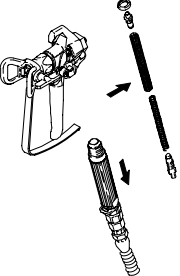
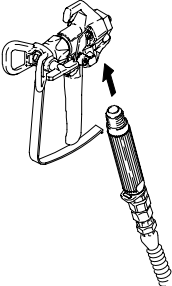
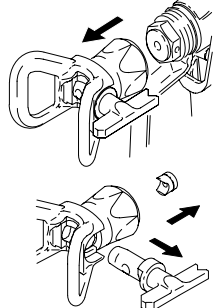
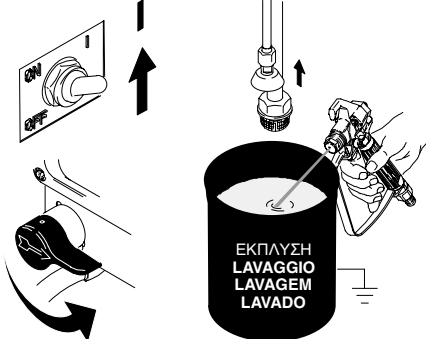

ΑΝΤΙΚΑΤΑΣΤΑΣΗ ΧΡΩΜΑΤΟΣ / CAMBIO DI VERNICE TROCA DE TINTA / CAMBIAR DE PINTURA

<p>1</p> <p>Εκτόνωση Πίεσης Scaricare la pressione Alívio de pressão Descompresión</p>	<p>2</p> <p>Προέγχυση Lavaggio Lavagem Lavado</p>	<p>3</p> <p>Προέγχυση Adescamento Ferrar Cebado</p>
--	--	--

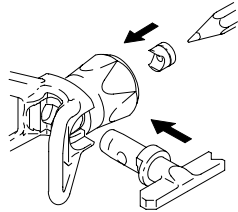
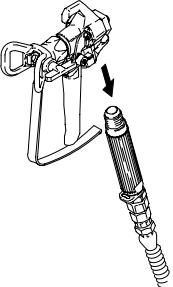
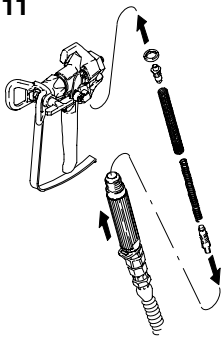
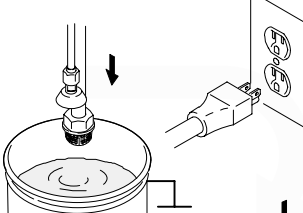
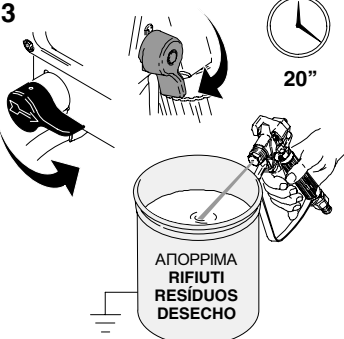
ΤΕΡΜΑΤΙΣΜΟΣ ΛΕΙΤΟΥΡΓΙΑΣ / SPEGNIMENTO / PARAGEM / PARADA

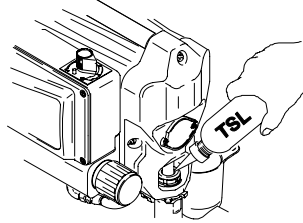
<p>1</p>  <p>MPa/bar/PSI</p> <p>Εκτόνωση Πίεσης Scaricare la pressione Alívio de pressão Descompresión</p>	<p>2</p>  <p>ΠΡΟΒΙΔΑΠΟΙΗΣΗ ADVERTENCIA</p> <p>PERICOLO ADVERTENCIA</p> 	<p>3</p> 	<p>4</p> 	
<p>5</p> <p>Προέγχυση Lavaggio Lavagem Lavado</p>	<p>6</p>  <p>ΕΚΠΛΥΣΗ LAVAGGIO LAVAGEM LAVADO</p> <p>20"</p>	<p>7</p>  <p>MPa/bar/PSI</p> <p>Εκτόνωση Πίεσης Scaricare la pressione Alívio de pressão Descompresión</p>		
<p>8</p>  <p>ΕΚΠΛΥΣΗ LAVAGGIO LAVAGEM LAVADO</p>	<p>9</p> 	<p>10</p> 	<p>11</p> 	<p>12</p>  <p>Διαλύτες πετρελαίου Acqua ragia minerale Diluyente Alcoholes minerales</p>
<p>13</p>  <p>ΑΠΟΡΡΙΜΑ RIFIUTI RESÍDUOS DESECHO</p> <p>20"</p>	<p>14</p>  <p>MPa/bar/PSI</p> <p>Εκτόνωση Πίεσης Scaricare la pressione Alívio de pressão Descompresión</p>	<p>15</p>  <p>Διαλύτες πετρελαίου Acqua ragia minerale Diluyente Alcoholes minerales</p>	<p>16</p> 	

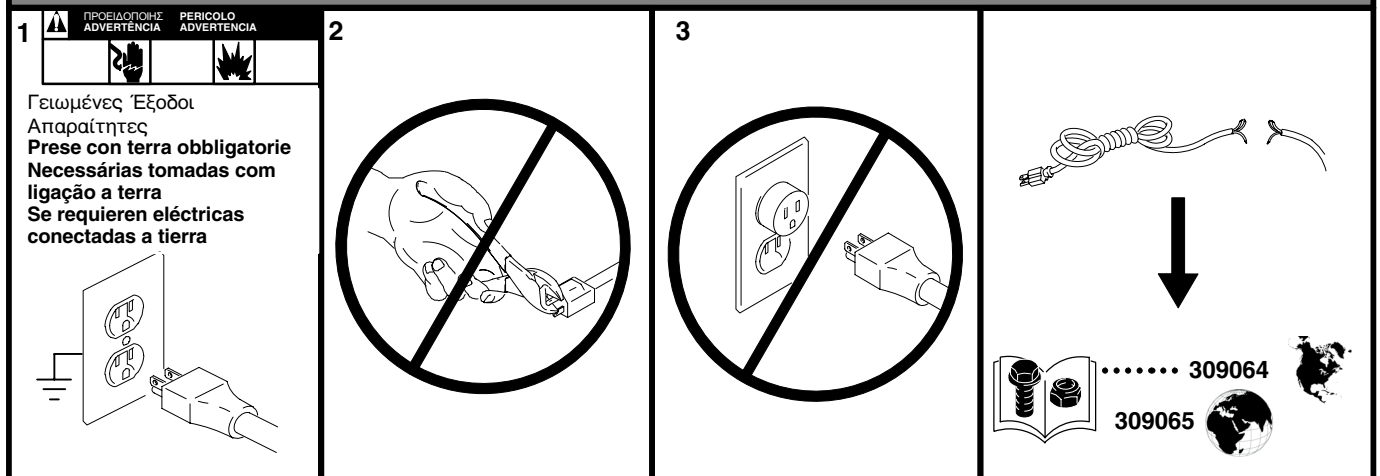

Θόρυβος / Interferenza / Ruído / Ruido

Ισχύς / Alimentazione / Potência / Potencia 87 dB(A)*

Πίεση / Pressione / Pressão / Presión 75 dB(A)*

* ISO 3744

Βασική Εγγύηση Graco Garanzia standard Graco Garantia Standard da Graco Garantía estándar de Graco

Graco warrants all equipment referenced in this document which is manufactured by Graco and bearing its name to be free from defects in material and workmanship on the date of sale by an authorized Graco distributor to the original purchaser for use. With the exception of any special, extended, or limited warranty published by Graco, Graco will, for a period of twelve months from the date of sale, repair or replace any part of the equipment determined by Graco to be defective. This warranty applies only when the equipment is installed, operated and maintained in accordance with Graco's written recommendations.

This warranty does not cover, and Graco shall not be liable for general wear and tear, or any malfunction, damage or wear caused by faulty installation, misapplication, abrasion, corrosion, inadequate or improper maintenance, negligence, accident, tampering, or substitution of non-Graco component parts. Nor shall Graco be liable for malfunction, damage or wear caused by the incompatibility of Graco equipment with structures, accessories, equipment or materials not supplied by Graco, or the improper design, manufacture, installation, operation or maintenance of structures, accessories, equipment or materials not supplied by Graco.

This warranty is conditioned upon the prepaid return of the equipment claimed to be defective to an authorized Graco distributor for verification of the claimed defect. If the claimed defect is verified, Graco will repair or replace free of charge any defective parts. The equipment will be returned to the original purchaser transportation prepaid. If inspection of the equipment does not disclose any defect in material or workmanship, repairs will be made at a reasonable charge, which charges may include the costs of parts, labor, and transportation.

THIS WARRANTY IS EXCLUSIVE, AND IS IN LIEU OF ANY OTHER WARRANTIES, EXPRESS OR IMPLIED, INCLUDING BUT NOT LIMITED TO WARRANTY OF MERCHANTABILITY OR WARRANTY OF FITNESS FOR A PARTICULAR PURPOSE.

Graco's sole obligation and buyer's sole remedy for any breach of warranty shall be as set forth above. The buyer agrees that no other remedy (including, but not limited to, incidental or consequential damages for lost profits, lost sales, injury to person or property, or any other incidental or consequential loss) shall be available. Any action for breach of warranty must be brought within two (2) years of the date of sale.

GRACO MAKES NO WARRANTY, AND DISCLAIMS ALL IMPLIED WARRANTIES OF MERCHANTABILITY AND FITNESS FOR A PARTICULAR PURPOSE, IN CONNECTION WITH ACCESSORIES, EQUIPMENT, MATERIALS OR COMPONENTS SOLD BUT NOT MANUFACTURED BY GRACO. These items sold, but not manufactured by Graco (such as electric motors, switches, hose, etc.), are subject to the warranty, if any, of their manufacturer. Graco will provide purchaser with reasonable assistance in making any claim for breach of these warranties.

In no event will Graco be liable for indirect, incidental, special or consequential damages resulting from Graco supplying equipment hereunder, or the furnishing, performance, or use of any products or other goods sold hereto, whether due to a breach of contract, breach of warranty, the negligence of Graco, or otherwise.

ΓΙΑ ΠΕΛΑΤΕΣ ΤΗΣ GRACO ΒΡΑΖΙΛΙΑΣ/ΚΑΝΑΔΑ/ΚΟΛΟΜΒΙΑΣ

Τα μέρη αναγνωρίζουν την εντολή τους για τη σύνταξη στην αγγλική γλώσσα του παρόντος εγγράφου, καθώς και του συνόλου των λοιπών εγγράφων, κοινοποιήσεων και νομικών πράξεων, τα οποία υπογράφονται, δίδονται, ή θεσπίζονται σύμφωνα με το παρόν ή σε άμεση ή έμμεση σχέση με το παρόν.

FOR GRACO BRAZILIAN/CANADIAN/COLUMBIAN CUSTOMERS

The Parties acknowledge that they have required that the present document, as well as all documents, notices and legal proceedings entered into, given or instituted pursuant hereto or relating directly or indirectly hereto, be drawn up in English.

PARA CLIENTES BRASILEIROS/CANADIANOS/COLOMBIANOS DA GRACO

As partes confirmam que solicitaram que o presente documento, assim como todos os demais documentos, notas e processos legais inseridos, atribuídos ou instituídos de acordo com o mesmo ou relacionados directa ou indirectamente com este documento, fossem redigidos em inglês.

PARA LOS CLIENTES EN BRASIL/CANADÁ/COLOMBIA

Las partes reconocen haber convenido que el presente documento, así como todos los documentos, notificaciones y procedimientos judiciales emprendidos, presentados o establecidos que tengan que ver con estas garantías directa o indirectamente, estarán redactados en inglés.

ΕΠΙΠΛΕΟΝ ΚΑΛΥΨΗ / COPERTURA GARANZIA AGGIUNTIVA / COBERTURA DE GARANTIA ADICIONAL / COBERTURA ADICIONAL DE LA GARANTÍA

Η Graco προσφέρει επαυξημένη εγγύηση και εγγύηση για φθορά για προϊόντα που περιγράφονται στο "Πρόγραμμα Εγγύησης Εξοπλισμών Graco".

La Graco non fornisce una garanzia estesa e garanzia contro l'usura per i prodotti descritti nel "Programma di garanzia per prodotti per professionisti Graco".

A Graco fornece prorrogação de garantia e garantia de desgaste para os produtos descritos no "Graco Contractor Equipment Warranty Program" (Programa de garantia de equipamento Contractor da Graco).

Graco proporciona una garantía extendida y una garantía que cubre el desgaste de los productos descritos en el "Programa de Garantía del Equipo Contractor de Graco".

ΓΙΑ ΠΑΡΑΓΓΕΛΙΕΣ Ή ΣΥΝΤΗΡΗΣΗ ΤΟΥ ΕΞΟΠΛΙΣΜΟΥ ΣΑΣ, αποταθείτε στον τοπικό σας διανομέα Graco,
ή καλέστε 1-888-541-9788 για να βρείτε τον πλησιέστερο διανομέα.

PER EFFETTUARE UN ORDINE O PER ASSISTENZA, contattare il distributore Graco, oppure chiamare il numero
1-888-541-9788 per identificare il distributore più vicino.

PARA EFECTUAR ENCOMENDAS OU PARA ASSISTÊNCIA TÉCNICA, contacte o seu distribuidor da Graco.

PARA REMITIR UN PEDIDO O SOLICITAR SERVICIO, póngase en contacto con el distribuidor de Graco.

Το σύνολο των στοιχείων που περιέχονται στο παρόν έγγραφο υπό μορφή κειμένου και εικόνων αποτελούν τις πλέον πρόσφατες πληροφορίες σχετικά με τα προϊόντα μας κατά τη χρονική στιγμή της έκδοσης. Η Graco διατηρεί το δικαίωμα να προβεί σε αλλαγές άνευ πρότερης ειδοποίησης.

Tutte le informazioni e le illustrazioni contenute in questo documento sono basate sulle informazioni più aggiornate disponibili al momento della pubblicazione. La Graco si riserva il diritto di apportare modifiche in qualunque momento senza preavviso.

Todo o texto e desenhos contidos neste documento reflectem as mais recentes informações sobre o produto disponíveis na altura da publicação.

A Graco reserva-se o direito de efectuar alterações em qualquer momento sem aviso prévio.

Todos los datos, escritos y visuales, contenidos en este documento reflejan la información más reciente sobre el producto disponible en el momento de su publicación, Graco se reserva el derecho de realizar cambios en cualquier momento, sin previo aviso.

Κέντρα Πωλήσεων: Μιννεάπολη, Νητρόιτ
Γραφεία Εξωτερικού: Βέλγιο, Κορέα, Χονγκ Κονγκ, Ιαπωνία
Uffici vendite: Minneapolis, Detroit
Uffici nel resto del mondo: Belgio, Corea, Hong Kong, Giappone
Escritórios de Vendas: Minneapolis, Detroit
Escritórios estrangeiros: Bélgica, Coreia, Hong Kong, Japão
Oficinas de ventas: Minneapolis, Detroit
Oficinas en el extranjero: Bélgica, Corea, Hong Kong, Japón

**GRACO N.V.; Industrieterrein — Oude Bunders;
Slakweidestraat 31, 3630 Maasmechelen, Belgium
Tel.: 32 89 770 700 – Fax: 32 89 770 777**

STAMPATO NEGLI USA 3X9059 11/1999, Revisionota 3/2001

IMPRESO EN EE.UU. 3X9059 11/1999, Revisado 3/2001

IMPRESSO NOS EUA 3X9059 11/1999, Revisado 3/2001

ΤΟ ΠΑΡΟΝ ΕΚΤΥΠΩΘΗΚΕ ΣΤΙΣ ΗΠΑ 3X9059 11/1999, Αναθεώρηση 12/1