



Operating manual **IC 110-E**

Table of contents

Your dry ice blasting equipment	3
Introduction and copyright	4
Process description	5
Technical data	6
Safety equipment	7
Operating the IC 110-E	8/9
Connecting the IC 110-E	10/11
Operating the blast gun	12
Putting into operation and decommissioning	13/14/15
Internal components of the equipment	16/17
Safety measures	18/19
Transportation	20
Repairs and warranty	20
Warranty conditions	21
Requirements for compressed air	21
Maintenance	21
Maintenance plan	22
Troubleshooting	23
Drawing	24
Electrical components	25
Wiring diagram	26
Material safety data sheet for dry ice	27

Your dry ice blasting equipment

Typ
Model
Modele

Nr.
No.
No.

Gewicht
Weight
Poids

Druck max.
Pressure max.
Pression max.

Baujahr
Manufacturing date
Annee de fabrication



ICS contact data:

ICS Ice Cleaning Systems s.r.o.
Robotnícka 2192
017 01 Považská Bystrica
Tel: +421-42-4261135
Fax: +421-42-4330248
Email: info@ics-dryice.sk

Introduction and copyright

This operating manual explains the safe and defect-free usage of the **IC 110-E** dry ice blasting equipment.

Every person operating this equipment must have fully read and understood the instructions given in this manual before putting the equipment into operation.

Please keep this manual safe and always at hand.

Failure to observe the procedures specified herein may lead to serious consequences both on the equipment and on its operators. The operator has to strictly observe the working procedures described herein. Any changes made to these work procedures have to be approved in writing by **ICS Ice Cleaning Systems s.r.o.**

The manufacturer of the equipment is not held responsible for damages caused to the system or generated by the system in the following cases:

- Non-observance of these working instructions
- Improper use or handling of the **IC 110-E**
- Repair and maintenance works performed by unauthorized persons
- Installation and replacement with **ICS** non-original parts
- Noncompliance with the requirements regarding compressed air.

The copyright to this operating instructions manual belongs to **ICS Ice Cleaning Systems s.r.o.**

This operating manual is intended for the operating and supervisory personnel. It contains regulations, illustrations and instructions, whose usage, fully or partially, by third parties is completely prohibited without an express written permission in this respect. Recommendations regarding the improvement of the machine or of the operating manual can be transmitted to

ICS Ice Cleaning Systems s.r.o.

The graphic representation of the blasting equipment can differ from the current delivery program, in certain individual details. Special accessories are partially represented at additional costs.

Process description

The dry ice blasting equipment **IC 110-E** operates with granules of dry ice pellets (\varnothing 3 mm), produced through the pressing of the CO₂ snow. The pellets are blasted on the surface to be cleaned. The dirt from the surface is frozen through thermal shock and it breaks because of the different expansion coefficients. The CO₂ granulate sublimates in the moment of impact from solid to gaseous state. Only the initial dirt remains behind.

The dry ice pellets in the hopper (\varnothing 3 mm) will be mixed using a compressed air operated dosing system, transported through the hose and accelerated through the blasting nozzle, the pellets can reach the speed of sound (depending on pressure and blasting nozzle).

before cleaning

dirty carrying material

Dirt

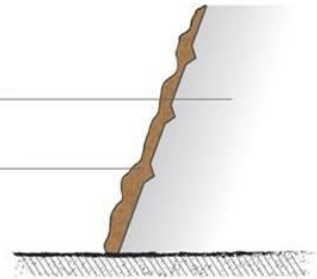

during cleaning

dry ice pellets

Dirt particles

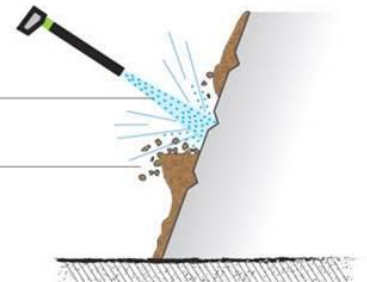

after cleaning

cleaned carrying material



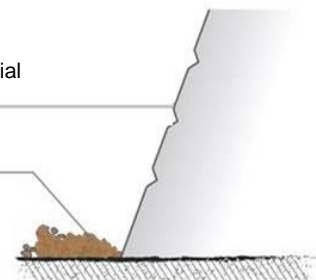



Dirt removed

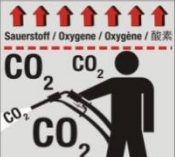

Technical data of **IC110-E**

Depth	500 mm (597 mm Trolley)
Width	337 mm (446 mm Trolley)
Height	614 mm (931 mm Trolley)
Weight	45 kg (49 kg Trolley) without hose package
Dry ice filling capacity	17 kg standard
Dry ice consumption	1-60 kg/h
Required working pressure	min. 1 bar – max. 10 bar
Compressed air consumption	0.3 m ³ /min – 4.5 m ³ /min, according to the nozzle combination used and the working pressure
Requirements for compressed air	The compressed air should be clean, dry and oil-free, meaning without foreign matter. Minimum requirements regarding compressed air quality according to ISO 8573-1:2010 [1:4:1]
Compressed air connection	Claw coupling DIN 3489
Power connection	100-240 V, 50/60 Hz, CEE 7/4 (type F)
Noise level	60-120 dB(A), according to the blast pressure, nozzle combination and the surface of the object to be cleaned

Safety equipment

BEI BETRIEB / DURING OPERATION / EN COURS DE FONCTIONNEMENT / 使用上の注意						
<p>WARNUNG / BEWARE ATTENTION / 注意</p>  <p>VERLETZUNGSGEFAHR DURCH CO₂ DANGER OF INJURY THROUGH CO₂ RISQUE DE BLESSURE PAR LE CO₂ ベレットによる怪我に注意</p>	<p>WARNUNG / BEWARE ATTENTION / 注意</p>  <p>Sauerstoff / Oxygene / Oxygène / 酸素 CO₂ CO₂ ERSTICKUNGSGEFAHR DANGER OF SUFFOCATION RISQUE DE SUFFOCATION 酸欠・CO₂中毒の 恐れあり</p>	<p>WARNUNG / BEWARE ATTENTION / 注意</p>  <p>ELEKTROSTATISCHE ENTLADUNG ELEKTROSTATIC DISCHARGE ÉLECTROSTATIQUE 静電気に注意</p>	<p>WARNUNG / BEWARE ATTENTION / 注意</p>  <p>VERBRENNUNGSGEFAHR EISTEMPÉRATUR -79°C DANGER OF INJURY ICE TEMPERATURE -79°C RISQUE DE BRÛLURE TEMPÉ- RATURE DE LA GLACE -79°C ドライアイス (-79°C) 取扱注意</p>	<p>WARNUNG / BEWARE ATTENTION / 注意</p>  <p>SICHT- UND GEHÖRSCHUTZ TRAGEN USE EYE AND EAR PROTECTION UTILISER IMPÉRATIVEMENTS DES PROTECTIONS POUR LES OREILLES ET LES YEUX 保護メガネ、耳栓着用厳守</p>	<p>WARNUNG / BEWARE ATTENTION / 注意</p>  <p>HANDSCHUHE TRAGEN WEAR GLOVES PORT DE GANTS OBLIGATOIRE 手袋着用厳守</p>	<p>WARNUNG / BEWARE ATTENTION / 注意</p>  <p>ARBEITSKLEIDUNG MIT LANGEN ÄRMELN TRAGEN WEAR LONG SLEEVED INDUSTRIAL CLOTHING PORT OBLIGATOIRE D'UNE COMBINATION À MANCHES LONGUES 長袖の作業着を着用</p>
<p>BEACHTEN SIE ALLE HINWEISE IM BEDIENHANDBUCH / ADHERE TO ALL INSTRUCTIONS IN OPERATING MANUAL / TOUTES LES INSTRUCTIONS DANS LE MANUEL 取扱説明書を必ず一読して下さい。</p>						

Before starting the work, the type of dirt and the support material have to be checked, in order to be able to take, if necessary, any additional safety measures, such as full protection measures.

In order to use the dry ice blasting equipment in safe conditions, you should always wear the following protection equipment:

1. Safety goggles
2. Ear protection
3. Long-sleeved work clothing
4. Protective gloves
5. Protective mask against dust
6. Safety footwear

Attention!

In poorly ventilated areas, a high concentration of CO₂ can lead to breathing difficulties and danger of suffocation. Therefore, you should always ensure that enclosed spaces are properly ventilated (exhaust air and fresh air supply).



When cleaning in silos, tanks or other similar spaces, ensure adequate air circulation or use additionally a breathing mask, which contains in the air supply line an activated carbon filter.



Operating the **IC110-E**

- (3) Equipment on/off (1) Main switch (2) Reset (4) Emergency shutdown



The Emergency shutdown (4) push-button immediately stops all functions of the equipment.

Attention!
Despite the emergency shutdown push-button has been ctuated, the equipment is supplied with compressed air and electricity!



After turning on the main switch (1), the reset push-button (2) will be actuated in order to activate the control. By actuating the equipment on/off switch (3), the **IC110-E** is ready for use.

Operating the **IC 110-E**

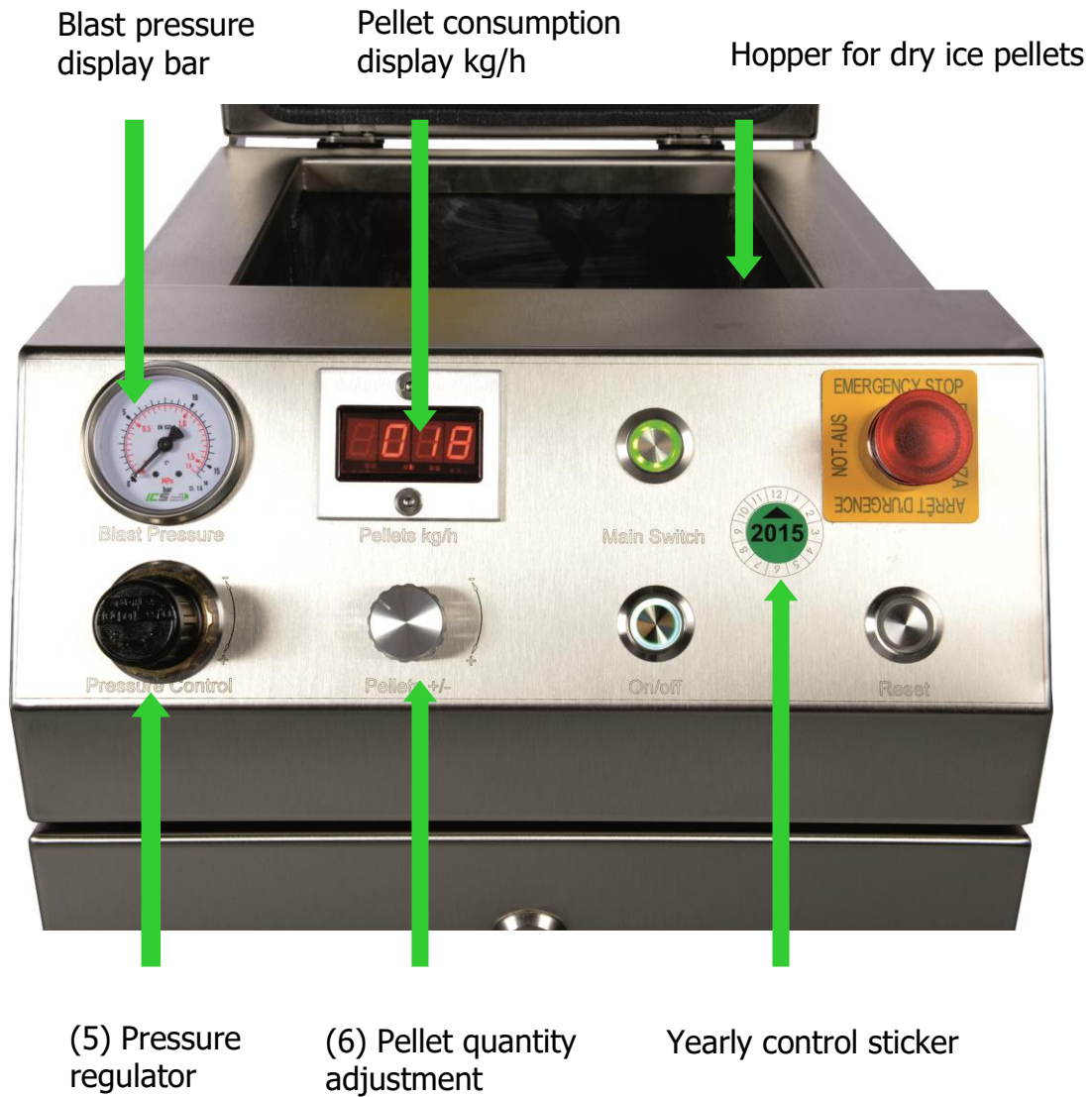

By using the pressure regulator (5), the blast pressure can be adjusted progressively between 1-10 bar.

The ice consumption is progressively adjustable between 1 – 60 kg/h by using the pellet quantity adjustment (6).

Connecting the IC110-E

Connections and components on the front side

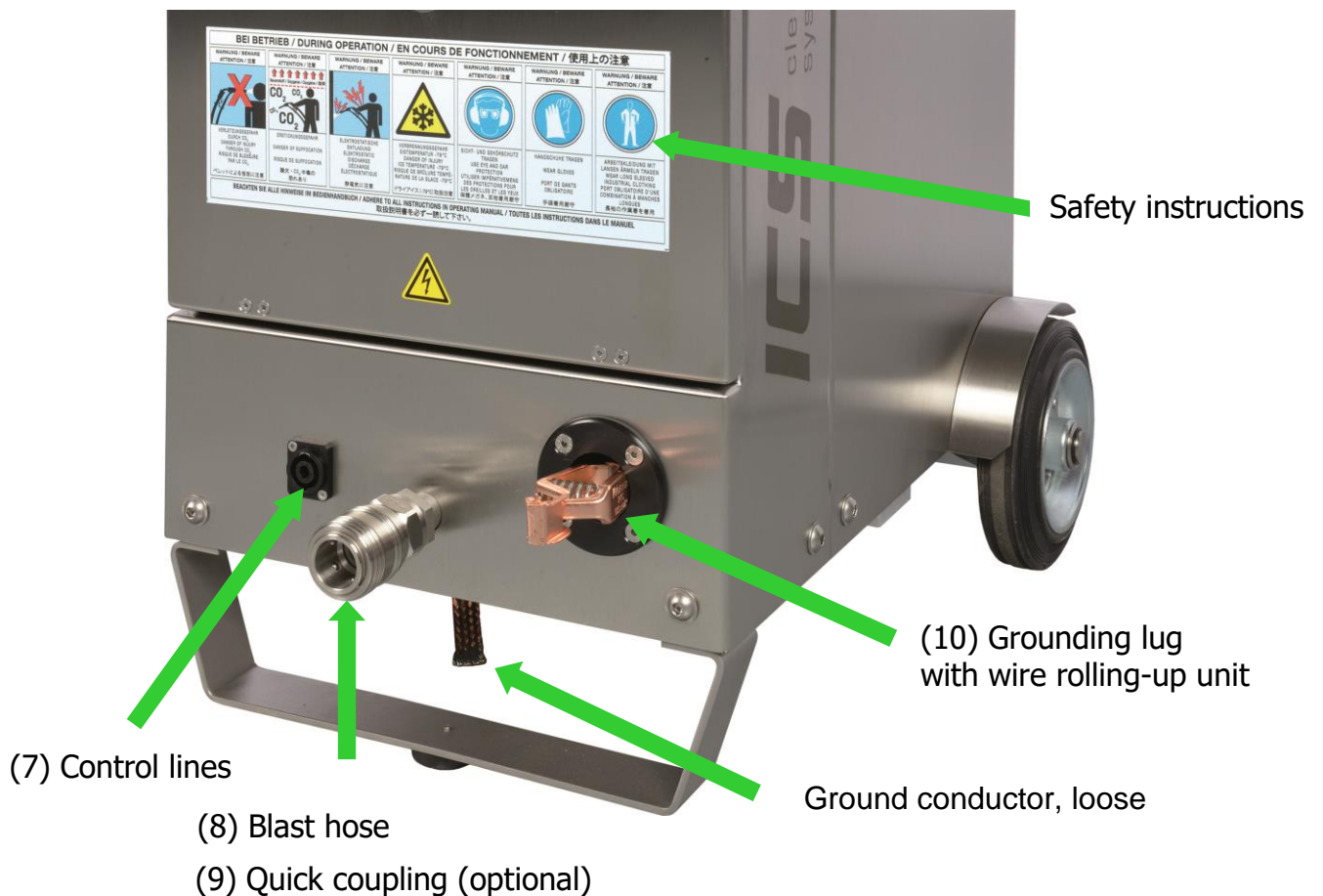

The blast hose connection (8) seals conically and can be connected or disconnected with a SW32 wrench.

If your equipment is provided with a **quick coupling (9)** (optional), push the outer ring towards the housing and insert the fitting of the blast hose until the ring snaps by itself in position. The closing is done in reverse order.

Please do not use this quick coupling as carrying aid during transportation!

The control lines (7) are simply inserted according to the diameter, up to the stop. To unlock, pull the silver bracket and turn the plug to the right, and after that take it out.

If you have problems with the static charges, additionally ground the machine with the **grounding lug (10)**, e.g. to a water conduit.

Connecting the **IC110-E**

Connections and components on the back side

Connect the compressed air hose using the **claw coupling** (11) by rotating the hose coupling in a clockwise direction until it snaps into place two times. In order to remove it, press the coupling of the unpressurised compressed air hose towards the machine and then turn to left.

Insert the plug of the **power cord** (12) and turn it to the right until it locks by itself. To unlock, pull the silver bracket and turn the plug to the left, and after that take it out. Insert the **grounded plug (type F)** in a suitable socket.

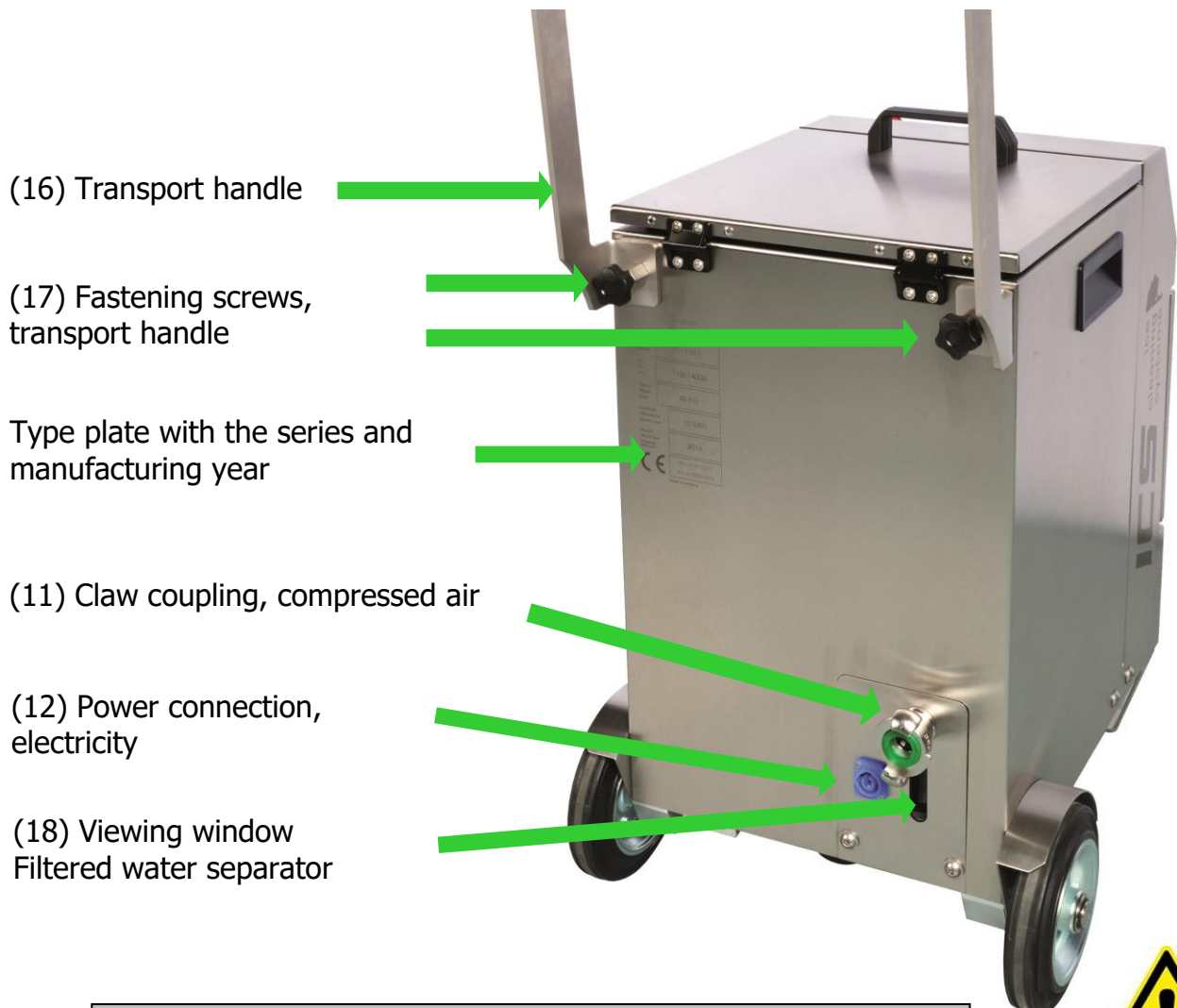

Attention!
Even when the main switch is off, the power cord is alive!



Operating the blast gun

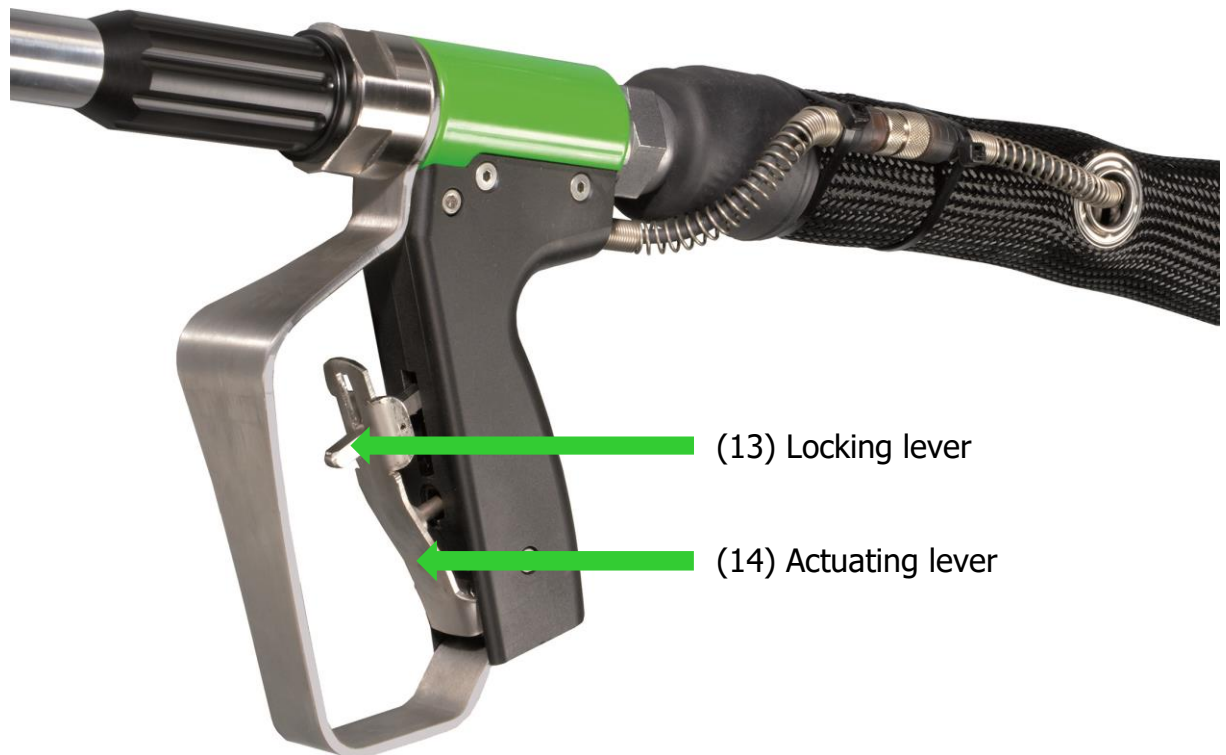

In order to trigger the blast gun, push the **locking lever** (13) upwards and pull the **actuating lever** (14) towards the handle. In order to stop the blast, release the **actuating lever** (14), it goes by itself back into the starting position.

Attention!
Always make sure you hold the gun safely and securely in your hand, so as not to endanger yourself or other persons.



Putting into operation

In order to put the **IC110-E** into operation proceed as follows:

1. Connect the compressed air hose first with the claw coupling (11) at the back of the blasting equipment and then to the compressed air source.
2. First, plug the power cable in the power connection (12) on the back of the blasting equipment and then into the power source.
3. Connect the blast hose of the hose package to position (8/9). Check the position of the quick coupling (9). Connect the control lines of the hose package to position (7).
4. On the control panel, push the main switch (1).
5. Push the reset button (blue) (2).
6. Actuate the On button (green) (3).
7. Open slowly the compressed air source!
8. Adjust the blast pressure from the pressure regulator (5).
9. Adjust the ice consumption from the pellet quantity adjustment (6).
10. Now actuate the gun for about 10 seconds towards the floor in order to blast the residual humidity out of the system.
11. Now fill the hopper with dry ice and close the lid to prevent any foreign objects getting inside the hopper.
12. Now the **IC110-E** is ready for use.





← Dry ice hopper

← Hopper grid, removable

Attention!
Make sure that during operation no one holds his hand into the hopper, because there are moving parts of the ice loosening system!



	WARNING MOVING PARTS CAN CRUSH AND CUT.
	WARNING Moving parts can create hand injuries.
	VAROVANIE POHYBLIVÉ ČASTI MÔŽU DRVIŤ A SEKAŤ.

Decommissioning

After completion of the blasting operations, proceed as follows:

1. Empty the dry ice from the hopper.
2. Close the compressed air source.
3. Actuate the gun to release the residual compressed air.
4. Actuate the Off button (green) (3).
5. Turn off the main switch (1).
6. Detach the power plug (12) and the air hose (11) from the equipment.
7. Disconnect the hose package (7/8/9) and roll it up.

Internal components of the equipment

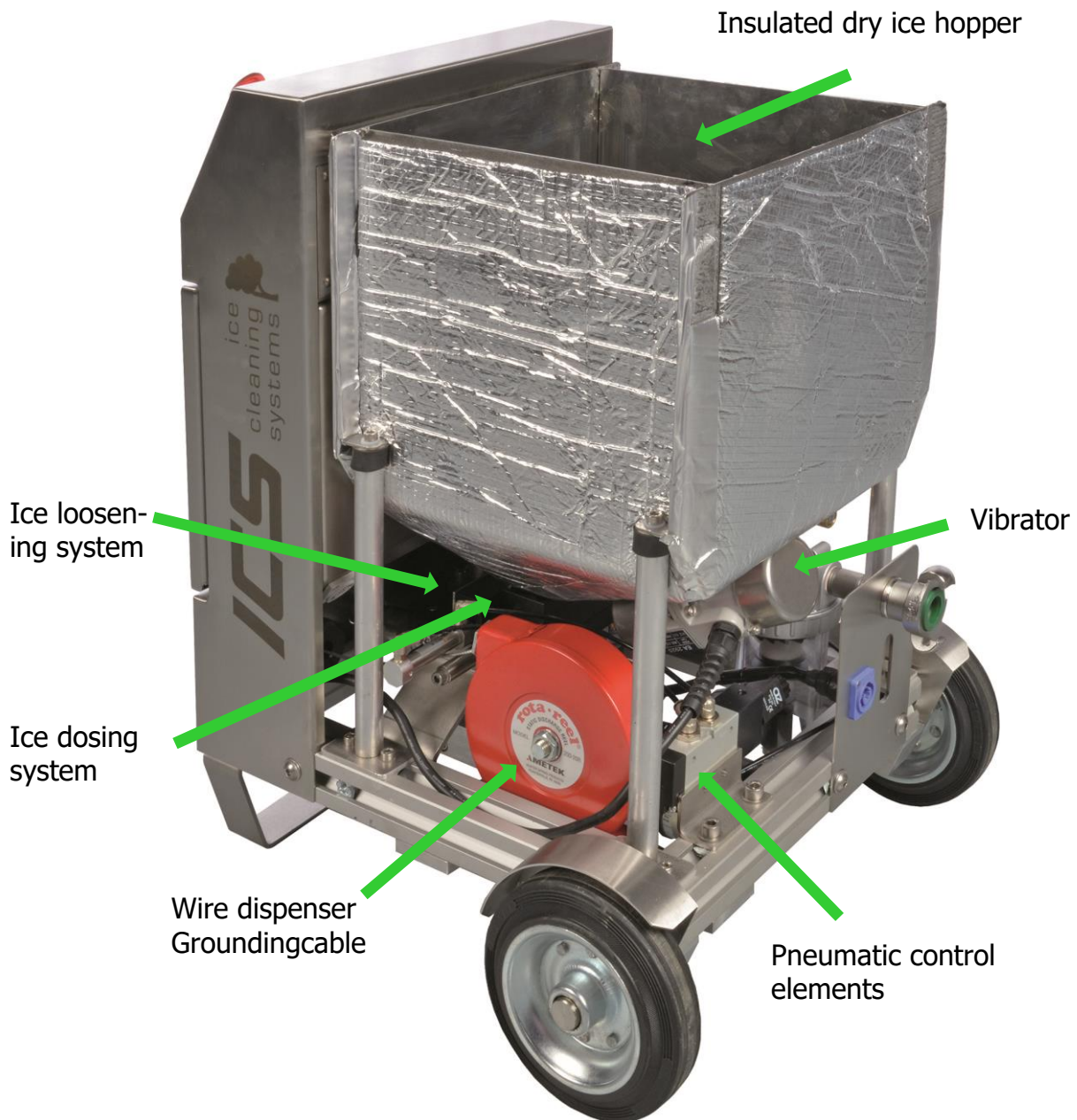

Internal components of the equipment

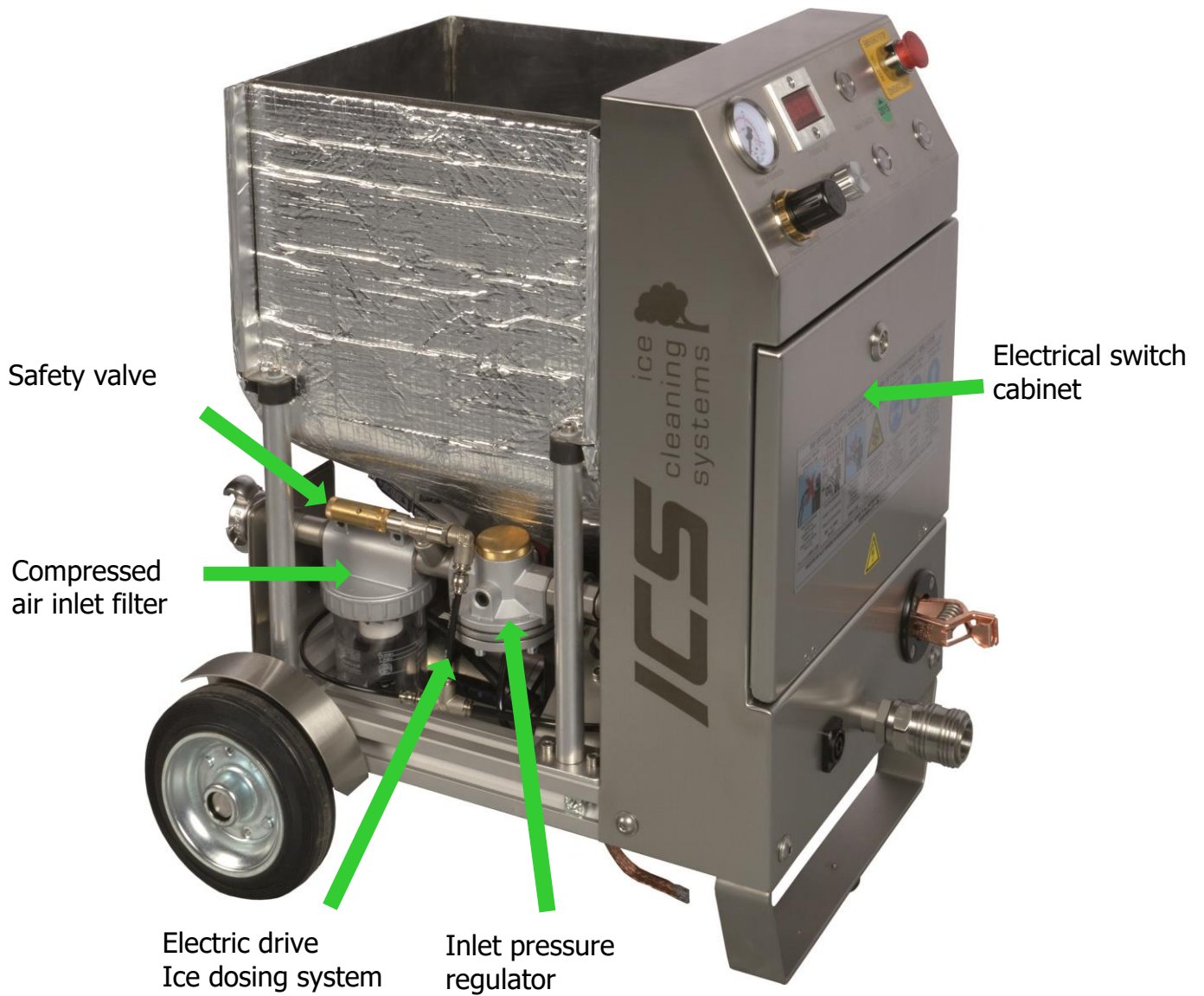

Safety measures Page 1 of 2

The safety measures are important both to you and to the operating personnel involved, and also for the use in optimal conditions of the **IC110-E**.

Ensure that the sockets are used according to the CEE 7/4 system, and if this is not possible, a separate earth conductor should be connected to the **IC110-E**. Ensure that the existing voltage corresponds with that mentioned on the type plate. The power cords should be fitted to as to be protected against damages, e.g. if people walk over them.

Before making any works at the **IC110-E**, the power plug has to be always taken out and the equipment has to be depressurised. Wait for 5 minutes so that any residual voltage dissipates.

Only free of damage compressed air hoses have to be used. The compressed air source is **slowly** opened after the successful connection to the equipment. From this point on, the **IC110-E** is pressurised and it cannot be left under any circumstances unsupervised.

When working with dry ice, the safety data sheet of the supplier has to be observed. Make sure that only dry ice can be found in the recipient. Always use gloves when handling dry ice, otherwise it may cause cryogenic burns.

**The temperature of dry ice is -79°C.
See the safety data sheet at the end of this manual.**



You always have to make sure that there is enough fresh air in the room, because CO₂ in gaseous state replaces the oxygen from the room.

Failure to observe this indication may represent a danger to life!

The MAK value (=maximum allowed concentration at which blasting is allowed for 8 h) is of 5,000 ppm. A CO₂ concentration in the air of over 8-10% (v/v) is **fatal**.

Note:

1 kg of dry ice pellets sublimates at blasting in approx. 0.5m³ CO₂

Safety measures Page 2 of 2

The dry ice shall not be kept in the hopper for more than 15 minutes, in order to avoid the freezing of the **IC110-E** equipment.

Still, if the hopper freezes, it has to be emptied manually. It is not allowed to press it with an object in order to loosen the ice pellets, because the dosing plate can become damaged.



The very high speed of the pellets can cause injuries. Therefore, blasting towards people or animals is prohibited. Never stretch your hand towards the blast, **high risk of injury!** Make sure that in the working area no unauthorised personnel is allowed.

The **IC110-E** has to be operated only by qualified personnel and after a detailed training, in order to avoid as much as possible the hazard potential and to ensure a smooth work flow.

The operator undertakes to use the **IC 110-E** equipment only when it is in perfect condition and to immediately remedy any kind of damages. (see page 20)

When using the **IC 110-E**, the local standards relating to security and accident prevention shall always apply.

Attention!

The blasting procedure shall not be carried out in areas with explosive air mixtures.



High electrostatic charges can develop. Always pay attention that the object which has to be cleaned should have earthing and this earthing should not be removed during the cleaning process. The **IC110-E** is provided with earthing from the gun, to the hose package up to the power plug.



The user should always wear **safety footwear class S2** or higher in order to protect himself from the static charge.

Persons having a **pacemaker** are **not** allowed to work with the **IC110-E**.



Transportation

For the simple transportation from one working place to another within your company, you are advised to use the transport handle (16 / see page 11).

For the transportation with a shipping company, the **IC110-E** equipment shall be fastened on a pallet using a strap and with the hoses rolled up.

After removing the fastening screws (17 / see page 11) and the transport handle (16), the blasting equipment becomes easier to handle during transport.

Repairs and warranty

Please bear in mind that the works, including the inspection and maintenance works, especially at the safety devices, can be carried out only by an **ICS technician or by a person who received special training for equipment and accessories of **ICS Ice Cleaning Systems GmbH** and who can present evidence in this respect.**

The potential repairs necessary during the warranty period have to be agreed upon beforehand with **ICS Ice Cleaning Systems GmbH**.

The spare parts which fall in the warranty period are replaced either at our location or are sent to you. The transportation costs, travel costs and costs related to the stay, as well as those for the disassembly and reassembly fall on the client.

For the evaluation of the warranty, the component or the equipment shall be sent to **ICS Ice Cleaning Systems GmbH**.

Warranty conditions

The warranty becomes void in the following cases:

- incorrect handling of the **IC110-E** equipment.
- using non-original spare parts.
- works at the **IC110-E** equipment carried out by unauthorised persons.
- using materials different than dry ice.
- noncompliance with the requirements regarding compressed air quality.

Carrying out unauthorised changed to the **IC110-E** equipment is prohibited!

The warranty period is 12 months after the delivery date. Excluded are rubber parts, wear parts and maintenance parts.

Requirements for compressed air

For an efficient blasting result, it is very important to use the proper quality of compressed air. The compressed air should be clean, dry, oil-free and without foreign matter.

For minimum requirements for compressed air quality we recommend those according to ISO 8573-1: 12010 [1:4:1] meaning

Particles =	Class 1 =	0.1 mg/m ³
Water =	Class 4 =	DTP 3 °C
Oil =	Class 1 =	0.01 mg/m ³

The pressure range of the **IC110-E** equipment is between 1 - 10 bar and the air volume between 0.3 – 4.5m³/min.

Maintenance

Thanks to its practical structure, the **IC110-E** equipment only requires a very low maintenance.

For the **IC110-E**, maintenance works should be performed on a regular basis at every 1,000 operating hours, and at least once a year. See the yearly control sticker (see page 9)

We recommend concluding a maintenance contract with **ICS Ice Cleaning Systems GmbH** or with an **ICS** authorised partner.

Maintenance plan for **IC 110-E** after 1,000 operating hours

1. General visual inspection of body, weld joints, chassis, tires, screw seat
2. If necessary, complete exterior and interior cleaning
3. Checking the functioning of the inlet pressure regulator and pilot pressure regulator
4. Cleaning control air filter, replacing filter
5. Checking the pneumatic control elements, checking for leaks and replacing the shock absorber
6. Complete electrical inspection, including contactors, voltage converter, frequency inverter, electric motor, firm seating of elements and terminals
7. Checking the entire ice dosing system for signs of wear, if it is functional and leak-proof
8. Checking the functioning and firm seating of the vibrator
9. Checking the ice loosening system, including the electro-pneumatic control, for signs of wear, if it is functional and safe for use
10. Checking the hose package for signs of wear, if it is functional and leak-proof (pressing)
11. Checking the connecting elements, connectors and pneumatic couplings for signs of damage, if they are functional and safe for use
12. Checking the blast gun if it is functional and safe for use
13. Checking the existing blasting nozzles for signs of wear and cracks
14. Pressure and safety test
15. Functional test
16. Blasting test
17. Replacing the inspection and maintenance plates

Troubleshooting

Problem	Description	Corrective action
The equipment cannot be started	The Reset button is lit despite actuation.	Unlock the Emergency Stop button by pulling it.
The equipment does not start	Nothing happens after the gun has been actuated.	Check whether the control line is blocked.
No air comes out from the gun	The equipment is running, but it does not blow out air.	Check the compressed air supply and the connection of the equipment and adjust the desired blast pressure at the equipment.
No ice comes out	After actuating the gun, only air and no ice comes out.	Place ice in the hopper. Set a minimum quantity of 10 kg/h.
The equipment is running, but no ice comes out	Ice is falling down on the lower part of the equipment	Blast pressure, amount of ice and the blasting tube are not optimally combined with one another and adjusted to each other.

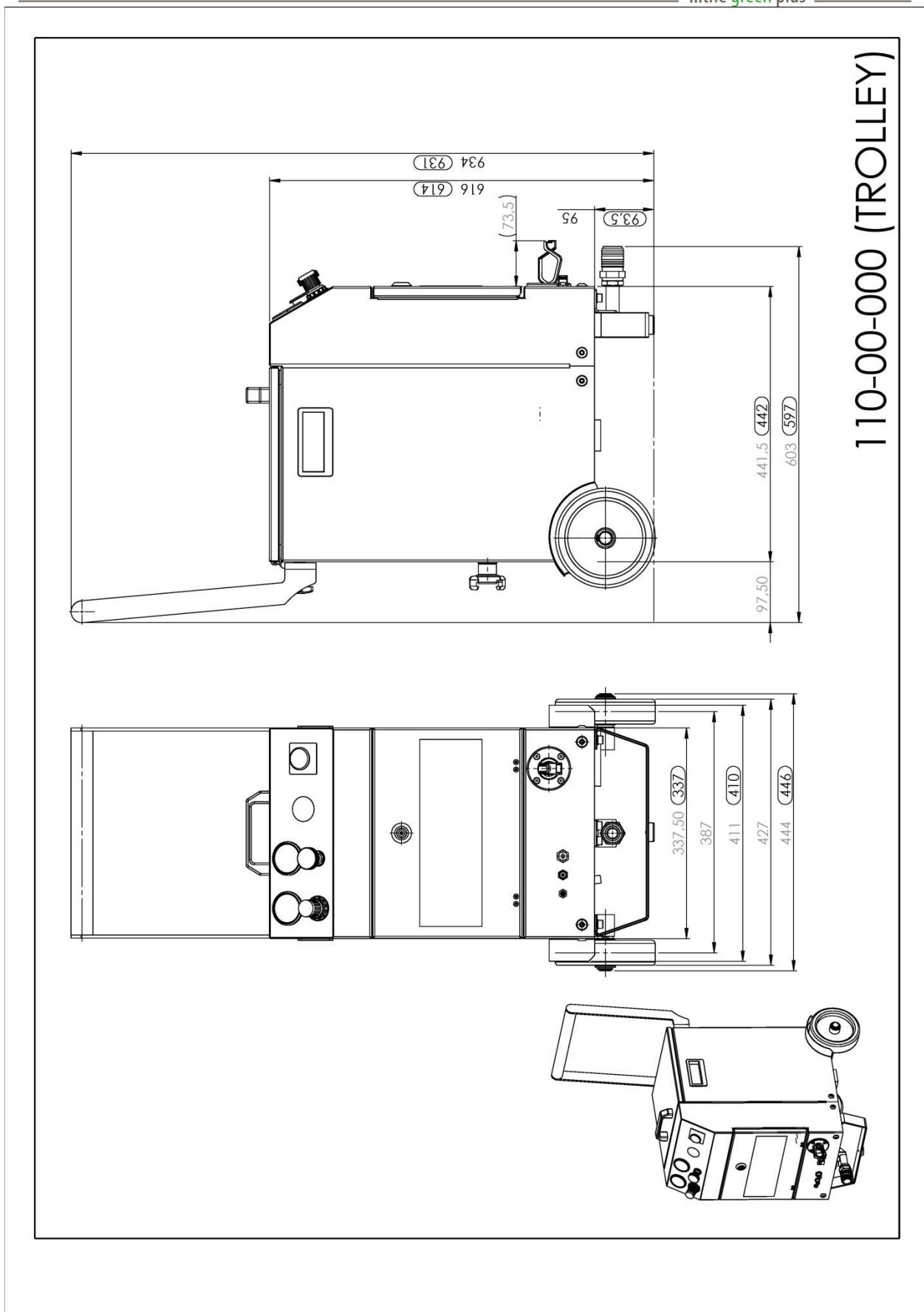

Electrical components

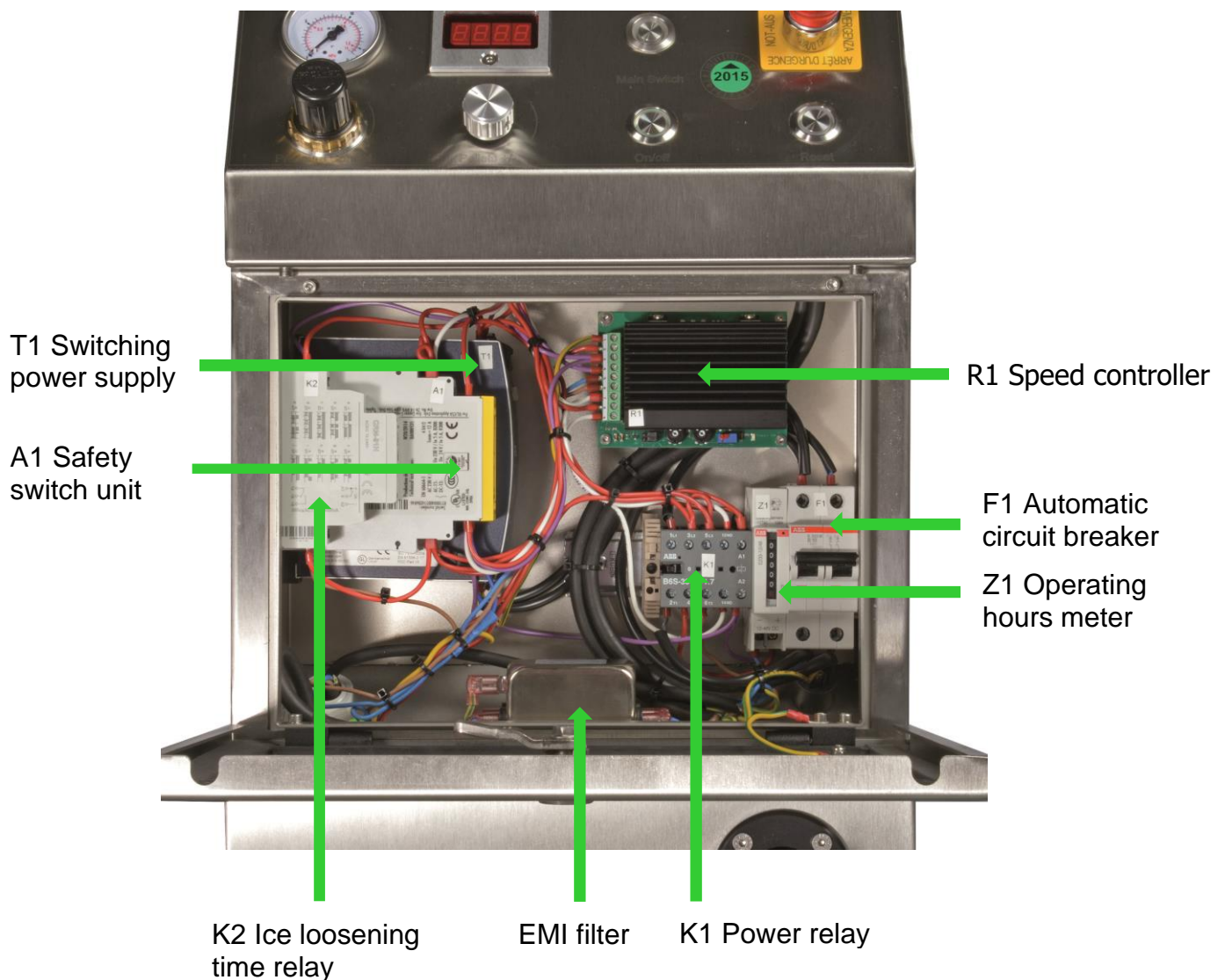

IC 110-E 100-230V

Kennung	Typ	Artikelbenennung
01	EMI-Filter	50162
02	Hauptschalter	50136
03	Sicherungsautomat	50148
04	Schaltezeitteil	50147
05	Sicherheitsschaltgerät	50153
06	Drehzahlsteller	50144
07	Digitalanzeige	50134
08	Vibrator	50365
09	Antrieb	50367
10	Schütz	50152
11	Zeitventil	50366
12	Luftventil 1/8"	50365
13	Luftventil 1/4" Norgren	50196
14	Zeitähler	50145
15	NOT AUS Taster	50142
16	Reset Taster	50141
17	NOT AUS Lampe	00000
18	Reset Lampe	00000
19	Ein Aus Schalter	50137
20	Ein Lampe	00000
21	Microschalter	50210
22	Potenziometer	50362

Auf der Anzeige Brücke B1 und B2 setzen!

R1 beide Jumper auf E

14.02.2014 K.K

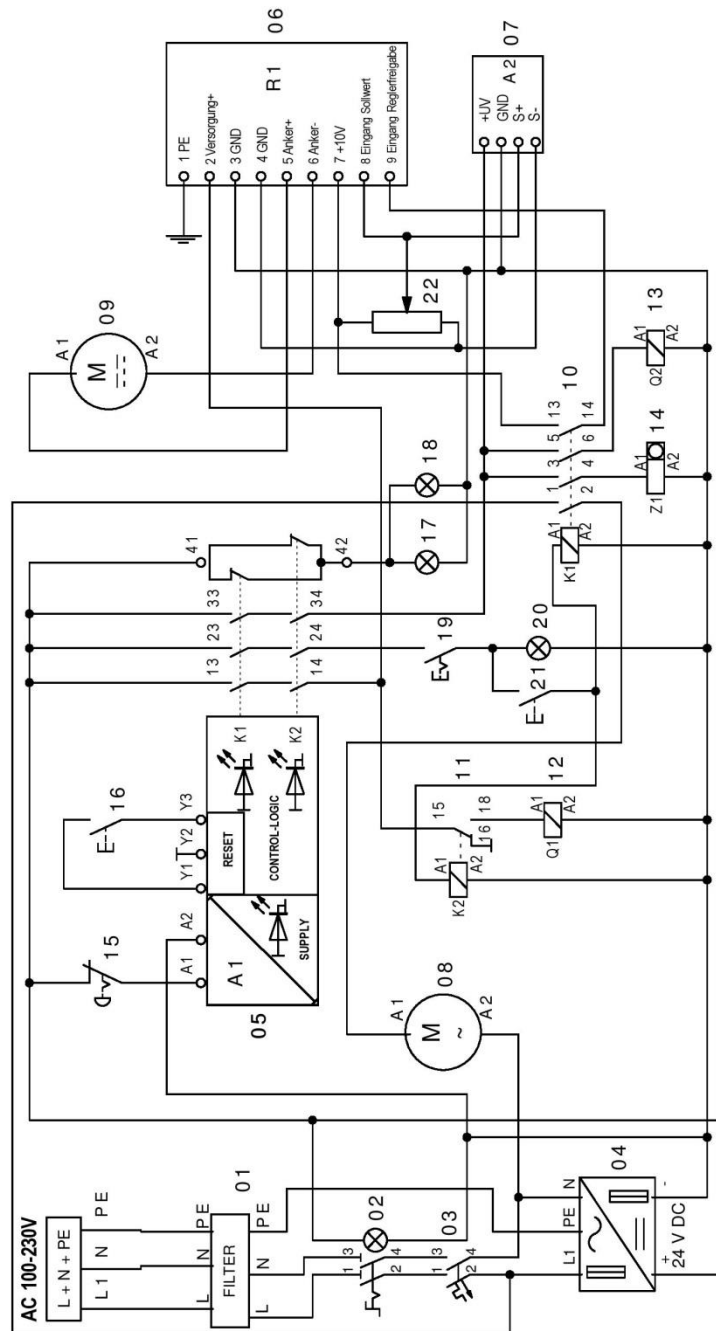

 Ice Cleaning Systems GmbH	Operating manual according to art. 14 of the Ordinance on Hazardous Substances Operating area: Working place:	Status: May 2012 (based on SDB 4/ 2005)
---	--	---

Identification of hazardous substance

Dry ice

Other designation: Carbon dioxide – in frozen state

CAS no.: 124-38-9

EU index no.: 204-696-9

Aggregate state: solid

Colour: white

Odour: inodorous

Flash point:

Boiling point: -78.5°C

Melting point: -56.6°C

Dangers for people and environment



Risk of frostbite development (-78°C) at skin contact

Risk of suffocation because of the sublimated vapours (from 1 litre of dry ice result 460 litres of gas)



Loss of mobility and consciousness

The gas released through evaporation is heavier than air and can accumulate in lower spaces.

First aid measure and rules of conduct

Protective measures:

- Avoid contact of the product with skin and eyes;
- During usage, ensure proper ventilation in the room;
- During the shredding operation, avoid dispersion of the chips;
- Do not transport with elevator if the elevator is being used by people;
- Avoid protrusion of the gas released by evaporation in the sewerage or in lower areas.



Eye protection:

Wear goggles with tight-closing system.



Hand protection:

Wear protective gloves made of leather or low temperature resistant gloves

Suitable extinguishing agents According to the conditions; carbon dioxide does not burn

Storage:

- not to be stored in basements and unventilated spaces;
- not to be stored in gas-tight containers (risk of bursting because of high pressure).

First aid measures

Injured persons have to be transported out of the danger area, using protection means, proper ventilation has to be ensured, in case of high concentration levels, a self-contained breathing apparatus has to be used.

Administering first aid

General information



After inhalation

Ensure proper ventilation, in case a person becomes unconscious, the victim should be positioned in a stable side position, in case of respiratory arrest administer artificial respiration, seek medical assistance.

In case of skin contact In case of frostbites, rinse for 15 minutes with lukewarm water.

In case of eye contact Rinse eyes for at least 15 minutes, afterwards see an ophthalmologist.

After swallowing

Drink plenty of water, seek medical assistance.

Appropriate disposal

The dry ice residues can be stored outdoors and left to evaporate, but only under strict supervision.

For additional information, contact the Labour Protection Department.