

# EcoQuip<sup>®</sup> Vapor Abrasive Blast System

334143A

EN

Wet abrasive blast system. For professional use only.

Not approved for use in European explosive atmosphere locations.

## Part No. EQ300S and EQ600S

Cart Mount with electric and pneumatic remote switch

*125 psi (8.6 bar, 0.86 MPa) Maximum Working Pressure*



### Important Safety Instructions







Read all warnings and instructions in this manual. Save these instructions.







EQ600S Shown

# Warnings

The following warnings are for the setup, use, grounding, maintenance, and repair of this equipment. The exclamation point symbol alerts you to a general warning and the hazard symbols refer to procedure-specific risks. When these symbols appear in the body of this manual or on warning labels, refer back to these Warnings. Product-specific hazard symbols and warnings not covered in this section may appear throughout the body of this manual where applicable.

 <b>WARNING</b>	
 	<p><b>DUST AND DEBRIS HAZARD</b></p> <p>Use of this equipment can result in the release of potentially harmful dust or toxic substances from the abrasive being used, the coatings being removed, and the base object being blasted.</p> <ul style="list-style-type: none"> <li>• For use only by sophisticated users familiar with applicable governmental safety and industrial hygiene regulations.</li> <li>• Use equipment only in a well-ventilated area.</li> <li>• Wear a properly fit-tested and government approved respirator suitable for the dust conditions.</li> <li>• Follow local ordinances and/or regulations for disposal of toxic substances and debris.</li> </ul>
 	<p><b>EQUIPMENT MISUSE HAZARD</b></p> <p>Misuse can cause death or serious injury.</p> <ul style="list-style-type: none"> <li>• Do not operate the unit when fatigued or under the influence of drugs or alcohol.</li> <li>• Do not exceed the maximum working pressure or temperature rating of the lowest rated system component. See <b>Technical Data</b> in all equipment manuals.</li> <li>• Do not use this equipment without hose coupling safety pins and whip checks installed on all air and blast hose couplings.</li> <li>• Do not blast unstable objects. The high amount of fluid flow from the nozzle can potentially move heavy objects.</li> <li>• Do not exceed load rating of lift eyes.</li> <li>• Do not operate equipment on or stand on an unstable support. Keep effective footing and balance at all times.</li> <li>• Use fluids and solvents that are compatible with equipment wetted parts. See Technical Data in all equipment manuals. Read fluid and solvent manufacturer's warnings. For complete information about your material, request MSDS from distributor or retailer.</li> <li>• Do not leave the work area while equipment is energized or under pressure.</li> <li>• Turn off all equipment and follow the <b>Pressure Relief Procedure</b> when equipment is not in use.</li> <li>• Check equipment daily. Repair or replace worn or damaged parts immediately with genuine manufacturer's replacement parts only.</li> <li>• Do not alter or modify equipment. Alterations or modifications may void agency approvals and create safety hazards.</li> <li>• Make sure all equipment is rated and approved for the environment in which you are using it.</li> <li>• Use equipment only for its intended purpose. Call your distributor for information.</li> <li>• Route hoses and cables away from traffic areas, sharp edges, moving parts, and hot surfaces.</li> <li>• Do not kink or over bend hoses or use hoses to pull equipment.</li> <li>• Keep children and animals away from work area.</li> <li>• Comply with all applicable safety regulations.</li> </ul>
	<p><b>BURN HAZARD</b></p> <p>Equipment surfaces and fluid that is heated can become very hot during operation. To avoid severe burns:</p> <ul style="list-style-type: none"> <li>• Do not touch hot fluid or equipment.</li> </ul>

# WARNING

 	<p><b>FIRE AND EXPLOSION HAZARD</b></p> <p>Flammable fumes, such as solvent, in work area can ignite or explode. To help prevent fire and explosion:</p> <ul style="list-style-type: none"><li>• Use equipment only in well ventilated area.</li><li>• Sprayer generates sparks. When flammable liquids are used near the sprayer or for flushing or cleaning, keep sprayer at least 20 feet (6 meters) away from explosive vapors.</li><li>• Keep work area free of debris, including solvent, rags and gasoline.</li><li>• Keep a working fire extinguisher in the work area.</li></ul>
	<p><b>PERSONAL PROTECTIVE EQUIPMENT</b></p> <p>You must wear appropriate protective equipment when operating, servicing, or when in the operating area of the equipment to help protect you from serious injury, including eye injury, inhalation of dust or chemicals, burns, and hearing loss. This equipment includes but is not limited to:</p> <ul style="list-style-type: none"><li>• Protective eye wear</li><li>• Protective shoes</li><li>• Gloves</li><li>• Hearing protection</li><li>• Properly fit-tested and government approved respirator suitable for the dust conditions</li></ul>
	<p><b>RECOIL HAZARD</b></p> <p>Blast nozzle may recoil when triggered. If you are not standing securely, you could fall and be seriously injured.</p>

## Table of Contents

	Page
Warnings	2
Blasting Tips	6
Check List Before Starting	7
Pressure Relief Procedure	8
Connecting the Blast Hose and Air Hose	9
Setting Up the Vapor-Abrasive Blast Unit	10
Using the Wash-Down Feature	18
Re-Filling the Pot with Abrasive	19
Shutting Down and Winterizing the Unit	20
Troubleshooting	24
Spare Parts Lists	38
Warranty	72

## Specifications and General Information

### Notes to Distributors and Owners

1. Verify that the OEM blast hose and nozzle, the dead man handle, the attached twin line, and the Operation and Maintenance Manual are included with the vapor-abrasive blaster when it is received. Verify that the OEM blast hose and nozzle, the dead man handle, the attached twin line, and the Operation and Maintenance Manual are included with the vapor-abrasive blaster when it is delivered to the purchaser.
2. This equipment is intended for knowledgeable and experienced users. No person or persons should be allowed to operate this equipment without first receiving proper training in vapor-abrasive blasting operation and use of this equipment. Immediately notify EcoQuip®, Inc. of any instances of use of this equipment in any manner other than the intended application.
4. Only qualified personnel should load and unload this equipment for shipping. Slings or other lifting devices must only be attached to the designated lifting points. There are 4 lift eyes. In addition there are 4 fork lift pockets (two that provide pallet jack access).
5. For further information contact:

EcoQuip, Inc.

525 Byron Street, Suite D

Chesapeake, VA 23320

Phone: 1-877-326-7847 (877ECOQUIP)

Fax: 1-757-689-0903

Website: [www.EcoQuip.com](http://www.EcoQuip.com)

### Important Reference Numbers

Fill in the Vapor-Abrasive Blaster model number, serial number, and other information in the blank spaces below. This information will be needed for reference when service, maintenance, or technical support is required.

Blaster Model Number \_\_\_\_\_

Blaster Serial Number \_\_\_\_\_ Water Pump S/N \_\_\_\_\_

# Blasting Tips:

**Blasting Hint #1**

For a consistent flow of water and abrasive, the auto-vent valve assures that there is no air in the pot during blasting. Engage the spring-loaded bung cross-pin to keep the bung open. First add at least 10 gallons (38 l) water, then add up to 500 lb (227 kg) media, then top off the pot to the bung seal with water. Disengage the bung pin to allow the bung to seal the pot. Turn the selector to the FILL position. This will force all of the trapped air out of the pot via the auto-vent valve—and then pressurize the pot.

**Blasting Hint #2**

When first learning the effects of the blaster, get a better understanding of the results by starting off at a shallow angle (closer to 0° than to 90°) and by keeping a good distance between the nozzle and the application. Observe the results, then reduce the distance, steepen the angle, and adjust the blast regulator. As the blast pressure is increased, fine-tune the Metering Valve. Try to achieve 7-10 pump cycles per minute. Keep in mind, the heavier and smaller the media particle (i.e. 80-grit), the more aggressive the results (unlike conventional blasting where use of 20-grit coal slag is common).

**Metering Valve Settings:**

There is no fixed formula for what works best in each application. The information below works best a majority of the time, and from this initial setting, adjustments can be made up or down to get the fastest removal rates without damage to the surface.

Normal settings are: 110 psi (7.5 Bar, 0.75 MPa) initial pot setting, **less than 1/2 turn open Metering Valve, blasting pressure at 80 psi (5.5 Bar, 0.55 MPa)**. For applications requiring higher performance, use high-performance media (the heaviest mass @ 80 grit) such as Garnet or Starblast®, and the highest pressures the compressor can support. The INITIAL pot pressure should always be 30 psi (2.0 Bar, 0.2 MPa) HIGHER than the intended blast pressure. Fine-tune the adjustments to meet the specific requirements for each application. Higher blast pressures will require turning the Abrasive Metering Valve slightly more open (and vice versa) – but make the adjustment result in 7-10 cycles per minute to be the most efficient (cut at the fastest rate while using the least amount of media). **Blasting pressures can range between 30 - 120 psi max (2.0 Bar, 0.2 MPa – 8.2 Bar, 0.82 MPa)**. Unlike conventional sandblasting, higher pressures do not necessarily mean better cleaning. **Nozzle distance and the angle to the surface has an effect on performance, as does the blast pressure. Choice of media also has a great effect. High-performance media produces the best performance and can save enough time to make up the difference in cost.**

**Blasting with 150+ feet of blast hose requires the use of an electric dead man handle.**

	Grit Size	Blast Pressure	Abrasive Dose	Blast Angle	Notes
<b>General</b>	40/70	60-80 psi (4.1 Bar, 0.41 MPa- 5.5 Bar, 0.55 MPa)	1/4 to 1/2 turns	35° - 65°	Increased blast psi = need to increase dose turns
<b>Wood</b>	80 (using a low-mass media like glass)	40-50 psi (2.7 Bar, 0.27 MPa- 3.4 Bar, 0.34 MPa)	1/8 to 1/4 turns	15° - 30°	No wash-down, as it may raise the wood grain. Brush off excess grains after the wood dries.
<b>Steel</b>	80-100 (using a high-mass media like Garnet)	100-120 psi (6.8 Bar, 0.68 MPa- 8.2 Bar, 0.82 MPa)	1/4 – 1/2 turns	65° - 85°	Increased blast psi = need to increase dose turns
<b>Fiberglass</b>	40-70 low mass	45-65 psi (3.1 Bar, 0.31 MPa- 4.4 Bar, 0.44 MPa)	1/8 to 1/4 turns	35° - 45°	Increased blast psi = need to increase dose turns

## **CHECK LIST BEFORE STARTING**

1. Check the compressed air supply according to its operator manual. Make sure the air being supplied is clean and relatively free of moisture and oil to prevent water contamination of the air control components.
2. Make sure air delivery valves are closed before the air supply compressor is started.
3. Make sure all required hose whip-checks and safety pins are in working condition and properly installed.
4. Make sure the equipment is situated on level ground. Failure to keep the unit on level ground will make it difficult or impossible to purge all of the air from the pressure vessel.
5. Make sure the water tank will remain fully supplied with clean water to avoid any possibility of the pump running dry during blasting.
6. Make sure the water filter or Y-screen (optional equipment) is properly serviced to avoid any possibility of pump cavitation during blasting.
7. Make sure to use the correct type of dead man handle. Blasting with 150 feet (45 m) or more of blast hose requires the use of an electric dead man handle. **NOTE:** An electric dead man handle can also be used on hose lengths below 150 feet (45 m).

# Pressure Relief Procedure



Follow the Pressure Relief Procedure whenever you see this symbol.

<p>This equipment stays pressurized until pressure is manually relieved. To help prevent serious injury from pressurized fluid, such as splashing fluid and moving parts, follow the Pressure Relief Procedure when you stop spraying and before cleaning, checking, or servicing the equipment.</p>						

Always de-pressurize the system prior to any repair.

1. Turn pot pressure regulator (PR) off.

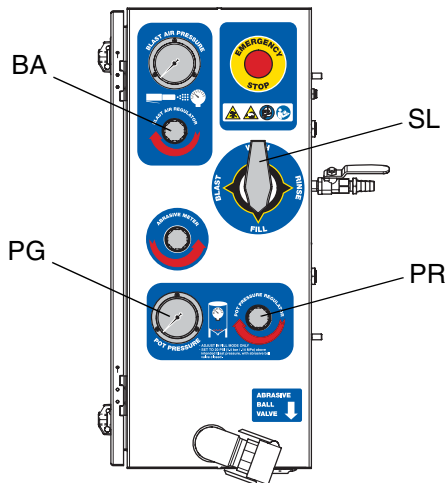

2. Turn the compressor OFF and disconnect the air inlet hose from the system.
3. Turn the 4-way selection (SL) to FILL position.
4. Open the dump valve on the blast tank.

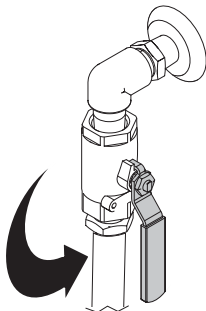

tii24112a

5. Verify that the pot pressure gauge (PG) displays zero pressure.

## CONNECTING THE BLAST HOSE & AIR HOSE

1. Always **purge** the air line before connecting the air line from the compressor (or on-site compressed air source) to the panel. Make sure to properly install a whip-check and safety pins or safety wires to the quick-coupler and the air line, if applicable. Always apply a hose whip-check across a quick-coupler connection and insert safety pins between the panel quick-coupler and the air line hose quick-coupler. If the holes do not align, there is something wrong and the two couplers are not compatible. **DO NOT TURN ON THE AIR.** Seek help to get the situation resolved.
2. Make sure the Blast Hose is laid out as straight as possible between the equipment and the work site. A coiled blast hose will uncoil under pressure and could cause a trip hazard or unintentional disconnect hazard. Sharp bends in the blast hose could cause the abrasive to wear through the hose and cause premature failure of the hose.
3. **Always turn the compressed air on BEFORE connecting the blast hose to the control box.** Make sure the rubber gasket in each coupler is in working condition. Always apply a hose whip-check across the connection and insert safety pins or safety wire between the panel coupler and the blast hose coupler. If the holes do not align, there is something wrong and the two couplers are not compatible. **DO NOT BLAST.** Seek help to get the situation resolved.
4. If you are using an electric dead man system, check all of the electrical connections from the panel to the dead man switch. Make sure no connection will be exposed to water, which could cause a short circuit.
5. Make sure the air supply pressure is at least 90 psi (6.2 Bar, 0.62 MPa) and not greater than 125 psi (8.6 Bar, 0.86 MPa), as shown on the gauge in the panel. If necessary, use a regulator in the supply air line to meet these specifications.

## SETTING UP THE VAPOR-ABRASIVE BLAST EQUIPMENT INITIAL SETUP AT BEGINNING OF SHIFT

1. Make sure the equipment is level and properly supported on a surface that can hold its total weight. With a full tank of water, a full pot of water, and abrasive, the EQ300/600 weighs 2900 lb (1315 kg). The weight of all personnel, the material being blasted, and any media being stored must also be considered.
2. Make sure that the pot is clean and free of any internal debris.
3. Flush water through the pot and out the disconnected Abrasive Hose Ball Valve before filling the pot with water and abrasive.

CRASH-CAGE VIEW



Always disconnect the abrasive hose at the cam & groove with the ball valve **closed**. If the pot contains water and abrasive (especially under pressure), releasing the cam and groove with the ball valve open will cause an unintentional release of abrasive.

**The Abrasive Ball Valve is shown in its CLOSED position. Confirm position BEFORE disconnecting quick-coupler.**

4. Close the Dump Valve.

The dump valve is shown in the **closed** position. When the handle is in-line with the hose, the valve is **open**.  
**NOTE:** Store the unit with all ball valves half open. This protects the valve seals in cold weather.



5. Close the Rinse Ball Valve.

**Rinse Ball Valve Location**  
Valve is shown in the closed position.  
The rinse function will only engage when the selector valve is in the OFF/RINSE position.



6. Make sure the Selector Valve and Rinse Valve are in the OFF position.



7. Make sure the E-Stop is pulled out. The water pump will not work unless the E-Stop is disengaged.



				
<p>The E-Stop will ONLY shut off the air control circuits inside the panel. It will not shut off the air supply source.</p> <p>Be aware of the location of the supply air line shut-off valve. A ruptured or disconnected air line could become a safety hazard if allowed to whip.</p>				

8. Make sure Abrasive Meter valve is closed. It will be set to approximately 1/4 turn open, later in the procedure.



9. Make sure the abrasive hose is connected and the Ball Valve is closed. Make sure the dump valve is closed.



SKID-MOUNT UNITS

Abrasive Hose Ball Valve is shown in the closed position. Rotate its handle 90° counter-clockwise (parallel to the hose) to open the ball valve.

10. Before adding any abrasive, add water to the pot for several minutes, to make sure the abrasive does not “dry-clog” in the pot or abrasive hose.

11. Align the bung handle with the pin slot, and then firmly push and turn the handle 90° after the pin is below the bracket slot. Proper engagement of the pin will hold the bung down until it is released.

Position prior to engaging pin



Spring compressed and pin engaged

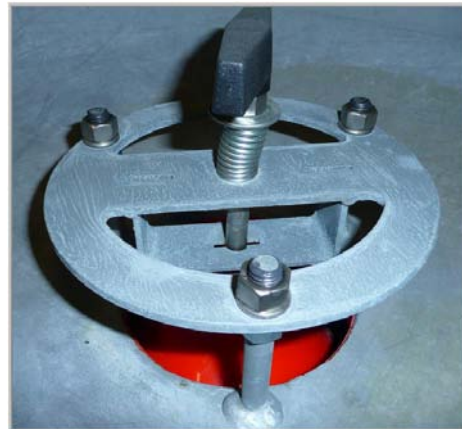

12. Wear a dust mask and add abrasive (minimum four bags, maximum ten 50 lb (23 kg) bags of high-mass media, or eight 50 lb (23 kg) bags of low-mass media). Use high-performance media for high-performance applications.
13. Use a garden hose or the Rinse Hose to wash the abrasive into the Pot and clear any media from the Bung and Bung Seal. When the water level reaches the bung seal, rotate the handle to release the bung pin (this will cause the bung to pop up against the seal).
14. Move the Selector Valve in the FILL position and add water to the Pot. If air can be heard venting from the auto vent, purging is in process.
15. The Auto Vent/Purge Valve will allow all of the air trapped in the top of the Pot to vent. When air stops venting, the Pot Pressure Gauge will start to register pressure.

The bung cannot be pushed down unless all of the pressure in the pot is released by opening the dump valve.

**NOTE:** Remove the cap from the vent port prior to filling the pot so the air can easily escape.

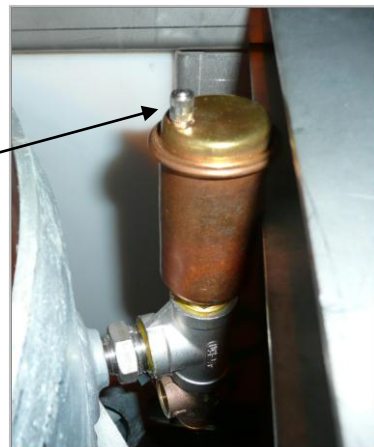

16. Make sure the water pressure in the Pot reaches the pre-set value, usually 100 - 110 psi (6.9 Bar, 0.69 MPa – 7.5 Bar, 0.75 MPa). Use the Pot Pressure Regulator to set the initial pot pressure 30 psi (2.0 Bar, 0.2 MPa) higher than the intended Blast Pressure.



Initial pot pressure is set using the POT PRESSURE REGULATOR, located next to the POT PRESSURE GAUGE. Initial Pot Pressure should be 30 psi (2.0 Bar, 0.2 MPa) higher than intended blast pressure. Pot Pressure SHOULD drop to blast pressure during blasting.

Pot pressure must only be set with the abrasive ball valve in the CLOSED position – never adjust pot pressure while blasting.

17. Move the Selector Valve to BLAST.



18. Gradually open the Abrasive Meter valve (1/4 turn or less).  
**NOTE:** Opening the valve too far will only waste abrasive and not improve performance.

19. Use the Blast Pressure Regulator to adjust pressure to the appropriate setting (use the chart on page 6 as a guideline). For the initial setting, leave the Abrasive Hose Ball Valve closed. Engage the Dead Man Handle and adjust the blast regulator until the gauge reaches the desired setting. Press and release the Dead Man Handle each time the blast regulator is adjusted.



20. Open the Abrasive Hose Ball Valve. Make sure the Pot pressure returns to the initial setting (it will not return to the initial setting if the Metering Valve is not slightly open). Close the dead man handle. **NOTE:** It may take up to one minute for abrasive to travel the inside length of the Blast Hose.
21. Fine-tune the Blast Pressure Regulator and Abrasive Meter valves while abrasive is blasting from the nozzle. Use a piece of test material similar to what you will be blasting. **NOTE:** Always start off as gently as possible and then increase the blast force as necessary to clean without doing any damage to the substrate. When properly set, the pump should cycle 7-10 times per minute.

**NOTE:** Close the Abrasive Hose Ball Valve whenever you stop blasting for more than 2-3 minutes. This will help to extend the service life of the diaphragm valve.

22. Always start gradually to assess the results without doing damage to the substrate. Approach the material to be blasted at a shallow angle so the blast and waste bounces away from the operator. Keep the Blast Nozzle a good distance from the application get familiar with the results. Then adjust the blast pressure, Nozzle angle, and the Nozzle distance from the application to make fine adjustments.
23. When blasting on a surface higher than the equipment, make sure that there is a length of blast hose on the ground equal to 10-20% of the height. For example: When blasting 50 feet (15 m) straight up, use at least 10 feet (3 m) of blast hose on the ground BEFORE the blast hose goes up to the blasting height. The hose on the ground prevents unspent media in the hose from back-filling the internal plumbing of the panel.

The following graphic will help explain this concept:

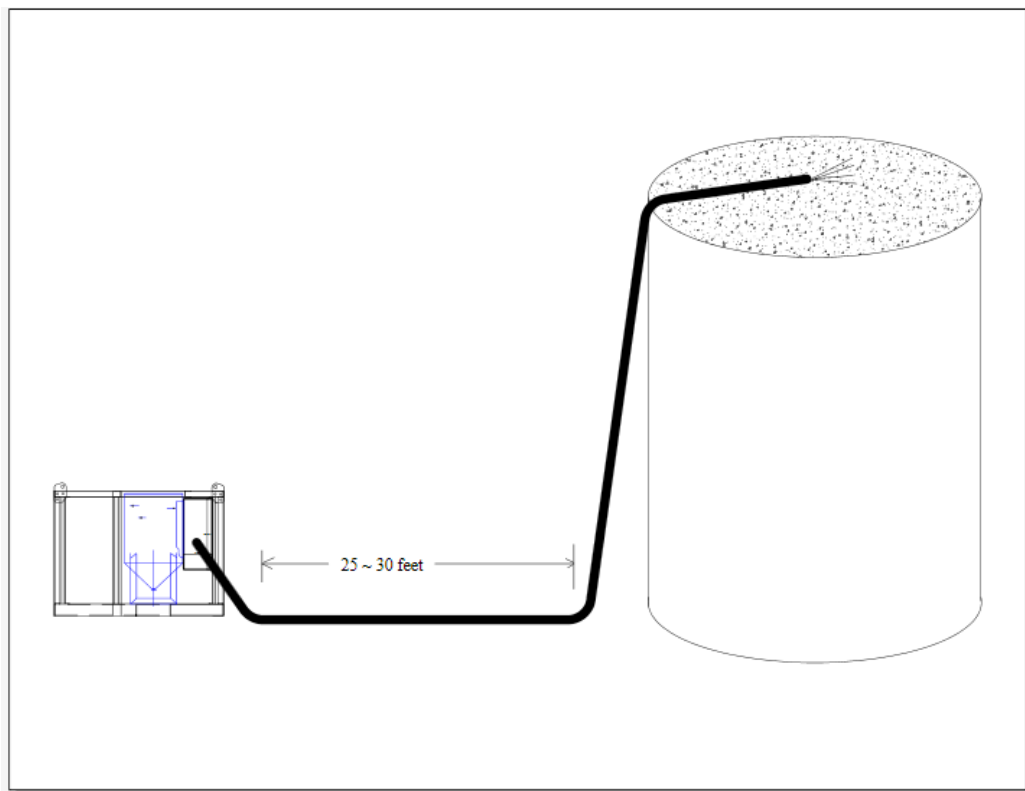

## USING THE WASH-DOWN FEATURE

1. Wash down feature causes air-driven water (without abrasive) to blast and rinse areas that have already been blasted with abrasive – it is also a convenient feature for flushing abrasive from the Blast Hose.
2. **NOTE:** There will always be some residual abrasive in the blast hose; never use the wash down feature on any surface other than where you have blasted, or intend to blast, as it WILL affect/dull the surface.
3. **NOTE:** Do not use the wash down feature on wood that has been blasted, as it could cause the grain to rise. Wait for the wood to dry and then use a broom, brush, or vacuum to remove any residual abrasive.
4. **NOTE:** Always use the wash down feature before going on break, especially when you are blasting at a higher level than the blasting unit – this is to prevent residual abrasive migrating backwards from the blast hose into the panel.
5. Make sure the Abrasive Hose Ball Valve is turned to the OFF position.
6. Position the Selector Valve in the WASH DOWN position.



7. Use the Dead Man Handle to control WASH DOWN in the same manner as you do when you blast.
8. After you wash down the blasted area, turn the Selector Valve to the OFF/RINSE position (with the abrasive ball valve still in the closed position). This will allow you to blast compressed air; however, there will always be some residual abrasive in the Blast Hose, so be very careful not to point the hose at any surface not intended to be blasted.

## **RE-FILLING THE POT WITH ABRASIVE**

- 1) Close the Abrasive Hose Ball Valve.
- 2) Position Selector Valve in the OFF position.
- 3) There is no need to adjust the Abrasive Meter.
- 4) Open the Dump Valve slowly to relieve the Pot water pressure.

**NOTE:** in some states, run-off is an issue – be prepared to capture the water that will be drained from the pot.

- 5) After all of the pressure in the POT has been relieved, engage the Bung pin by compressing the spring and turning the handle 90° to hold the bung in the open position.
- 6) Add abrasive (minimum four bags, maximum ten 50 lb (23 kg) bags of high-mass media or eight 50 lb (23 kg) bags of low-mass media) and continue the procedures from step 13 (page 14), SETTING UP THE VAPOR-ABRASIVE BLAST EQUIPMENT.

## SHUTTING DOWN

### SAVING THE ABRASIVE AT THE END OF THE JOB/SHIFT

#### WINTERIZING THE UNIT

- 1) When you have finished the blasting application, perform wash down (Abrasive Hose Ball Valve turned OFF) long enough so that all of the abrasive is flushed from the Blast Hose.
- 2) Position Selector Valve in the OFF position, and with the Abrasive Hose Ball Valve turned OFF, continue to blast until you no longer see water coming from the Blast Hose. This is to dry the inside of the hose for storage.
- 3) Estimate that a 5-gallon pail will be needed for each bag of abrasive still in the Pot.
- 4) Make sure you close the Abrasive Hose Ball Valve. There is still water pressure in the Pot and you need the ball valve closed in order to safely release the pressure.
- 5) Release the Cam Lock, between the Abrasive Hose Ball Valve and the control panel Groove, by removing the Safety Pins and pulling the rings out and up to pull the two cams away from the groove.
- 6) Holding a bucket under the panel Groove, turn the Selector Valve to the WASH DOWN position. This will flush the Groove.
- 7) Be sure to catch the unspent abrasive that will be washed out of the panel plumbing and out of the Groove fitting.
- 8) Turn the Selector Valve to the FILL/FLUSH position, as this will aid in pushing the abrasive out through the abrasive hose.
- 9) Place a bucket under the Abrasive Hose and slowly open the Ball Valve and catch the abrasive in buckets so it can be used for your next application.  
**NOTE:** Cover the buckets during storage so debris does not contaminate the abrasive.
- 10) Once the Pot pressure reduces (you will hear the pump speed up, indicating it can no longer keep up with the volume of water draining from the hose), turn the Selector Valve to the OFF position.
- 11) Engage the bung pin to hold the bung open and allow air to enter.

- 12) Continue flushing the Pot, using the Rinse Hose (or a garden hose if available) while aiming 360° around the Bung fill port in order to wash all of the internal sides and funnel of the Pot free from abrasive.
- 13) Drain the Water Tank to reduce any chance of water stagnating in the tank. Drain the water tank as far as possible. See following pictures.
- 14) NOTE:** In cold climates, always consider that the unit may be stored in non-heated storage, and determine if there is any possibility of freezing weather prior to the next time the unit is used – if in doubt, winterize the unit. Follow directions below:

## Winterizing EcoQuip Vapor-Abrasive Blast Equipment

Vapor-Abrasive Blasters **must** be winterized whenever there is a possibility of freezing temperatures during storage – even just overnight. It is imperative that you anticipate the possibility of a freeze and **always** protect the unit during fall and winter seasons – this includes every night whenever the unit is being used.

1. Normal operating position of the ball-valve is with the handle pointing in line with the suction hose going to the water pump. (This position is shown in the above picture – the handle must be in this position during operation.)
2. For DAILY operation with temperatures between 32° - 34° F (0° - 1° C), the water pump and tubing can be purged with air rather than doing the full (long-term) winterization shown in steps 10 thru 18.
3. Disconnect the water pump suction hose at the Quick Coupler at the bottom of the water pump. Due to the check valve inside the pump, this will not let all of the water out of the pump. You **MUST** complete steps 4 through 8 to protect the pump.
4. With the supply air still active, put the selector valve into the OFF position. Open the rinse ball-valve. Let the water pump run for 10 seconds.
5. Rotate the selector valve into the WASH DOWN position and run the pump for 5 seconds.
6. Rotate the selector valve into the BLAST position and run the pump for 5 seconds.

7. Rotate the selector valve into the FILL/FLUSH position and run the pump for 5 seconds.
8. Depress the E-Stop to stop the pump from running.
9. Return Selector to the OFF position and re-connect the suction line.
10. Turn off the air supply and release the pressure in the air system by briefly activating the dead man handle until the supply air pressure gauge shows zero. The pump should not run more than 30 seconds without water so as not to damage the seals.

For Temperatures **Below 32° F (0° F)**, Or For Long-Term Winter Storage, Start With Steps 11 Through 18

11. Make sure that all of the water has been drained from the pot. Leave the abrasive hose disconnected with its ball-valve at a 45° angle. Make sure the pop-up at the top of the pot is in the closed position. This will prevent debris from entering the pot during storage.
12. Drain the water tank by disconnecting the suction hose at the ball-valve and turning the handle so the handle points toward the open port. Follow all state and local laws, as "run-off" is not allowed in some locations. In addition, if the water contains a rust inhibitor, you may want to retain and preserve the water due to the expense of the inhibitor.



13. Drain the water pump suction hose and stick the end into a Windshield Wash container – choose a Windshield Wash with a rating that will protect the unit for the lowest temperatures in your area.

14. With the selector valve in the OFF position, open the RINSE ball-valve. While holding the rinse hose over the pot, run the pump until Windshield Wash comes out of the rinse hose. This will purge the pump and fill the pump with windshield wash to protect the pump.
15. Now move the selector into the other three positions (Wash Down, Blast, and Fill/Flush). Confirm that the internal water tubing fills with Windshield Wash before selecting the next position with the selector valve. All 3/8 in. tubing should be filled of Windshield Wash assuring full protection.
16. Pour the remaining windshield wash into the water tank, and then make sure that the rinse ball-valve and the drain ball-valve are set to a 45° angle.
17. Reconnect the suction hose to the water tank ball-valve.

**All ball-valves should be at a 45° angle to prevent ice from forming behind the seals, which would cause damage.**

Troubleshooting the EcoQuip® Equipment  
Table of Contents

1	<b>Pot Does Not Build Pressure</b>	25
2	<b>Dead Man Does Not Work - Pneumatic</b>	26
3	<b>Dead Man Does Not Work – Electric</b>	26
4	<b>Blast Pressure is Low and Will Not Adjust Up With Regulator</b>	27
5	<b>Blast Splutters or is Inconsistent</b>	28
6	<b>Pot Pressure Drops Below Blast Pressure and Continues to Drop</b>	29
7	<b>“Water-hammer” Effect Every Time You Start Blasting</b>	30
8	<b>No Blast, but Water Pump Runs When Dead Man Handle is Engaged</b>	31
9	<b>Blast Happens Without Engaging Dead Man</b>	31

# Troubleshooting

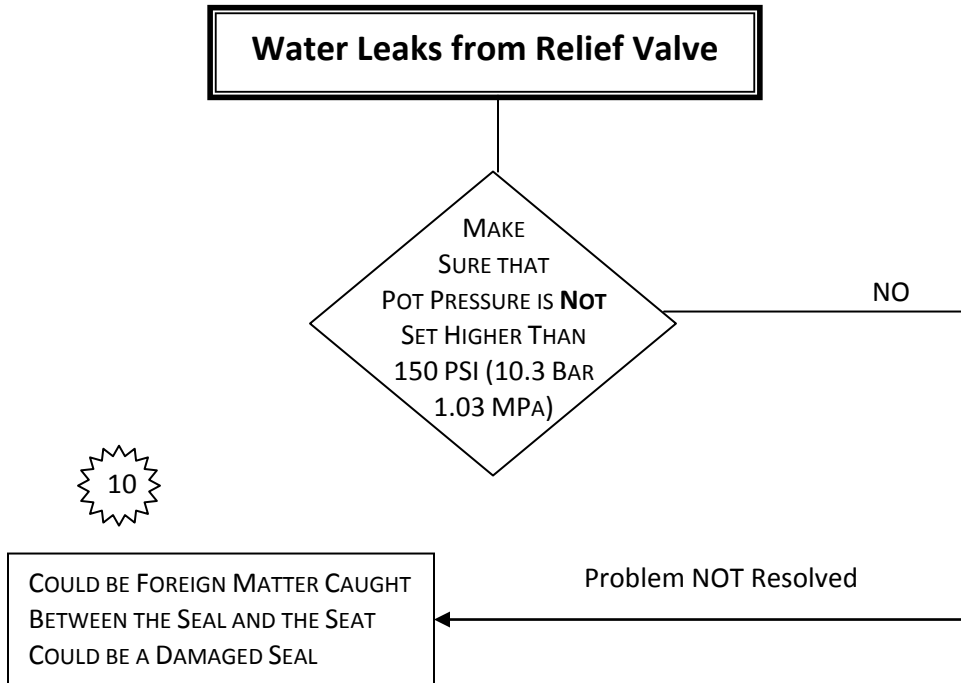
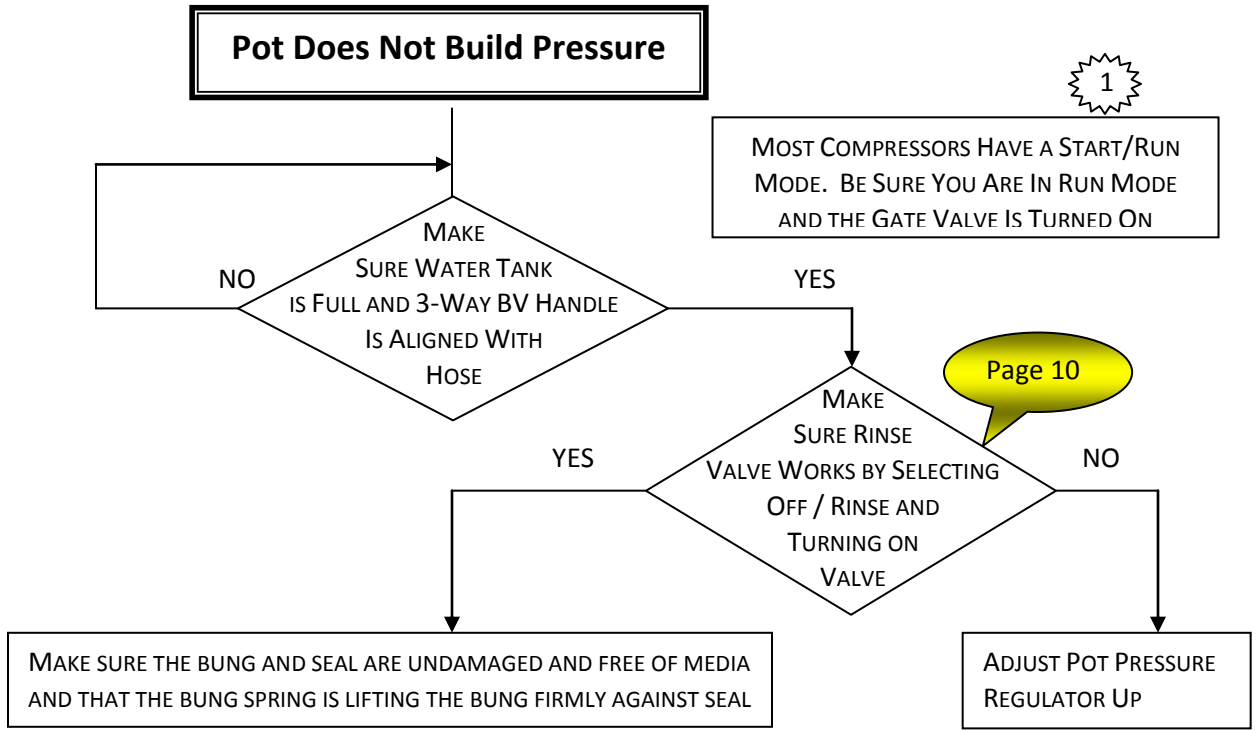

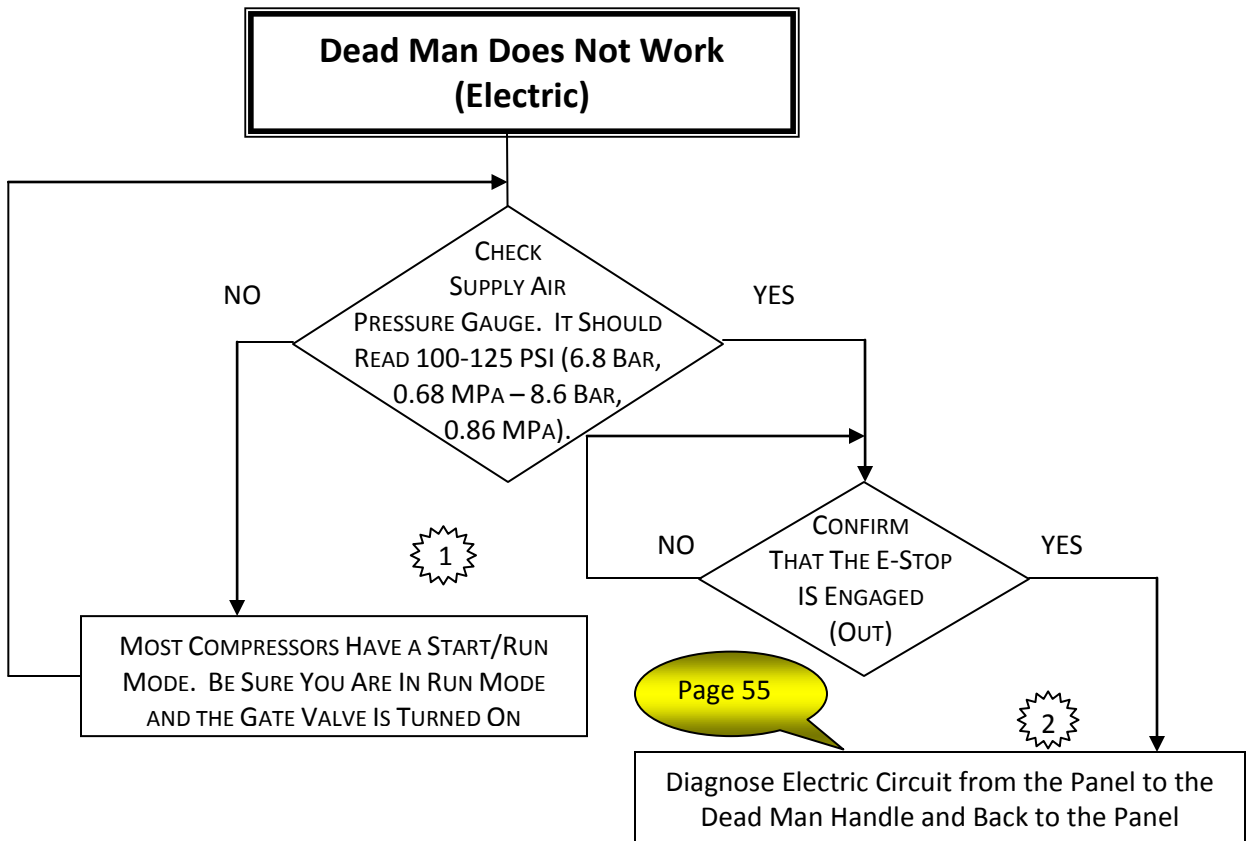
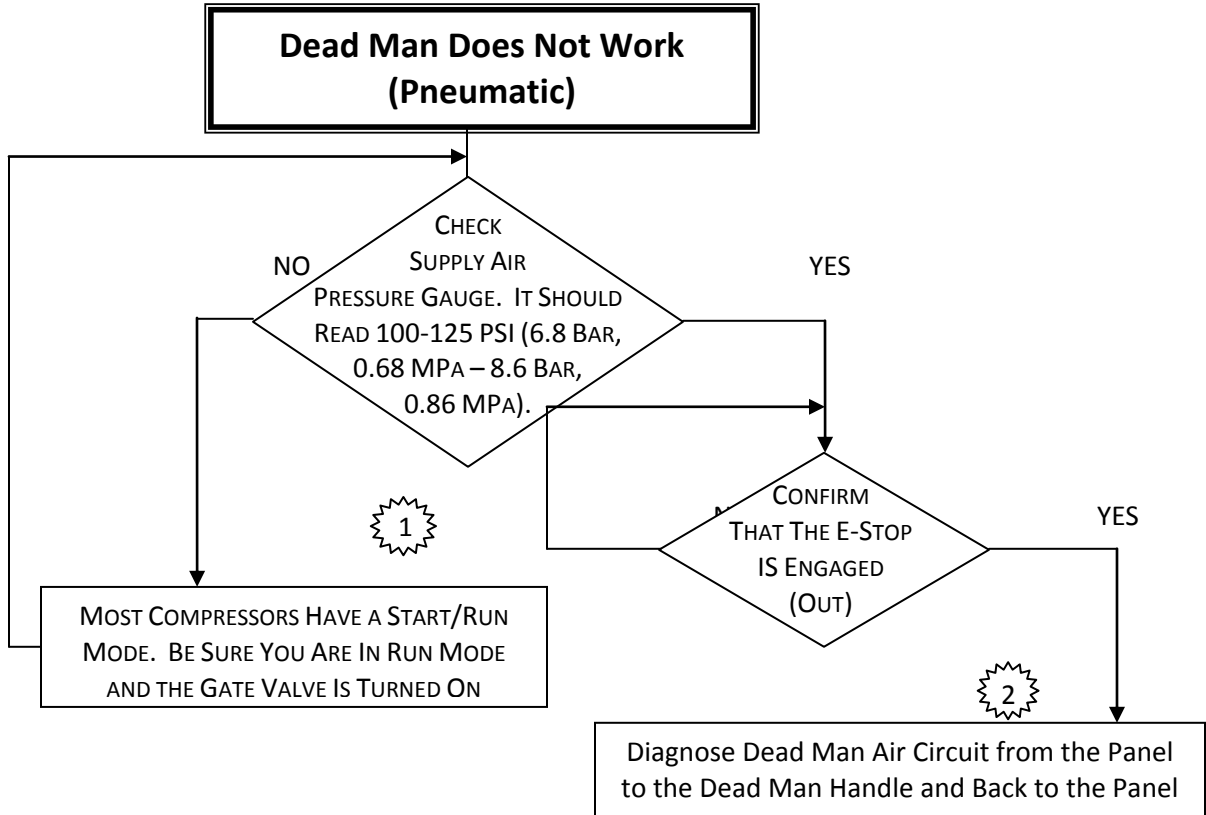

**Blast Pressure is Low and Will Not Adjust Up, Using Blast Regulator**

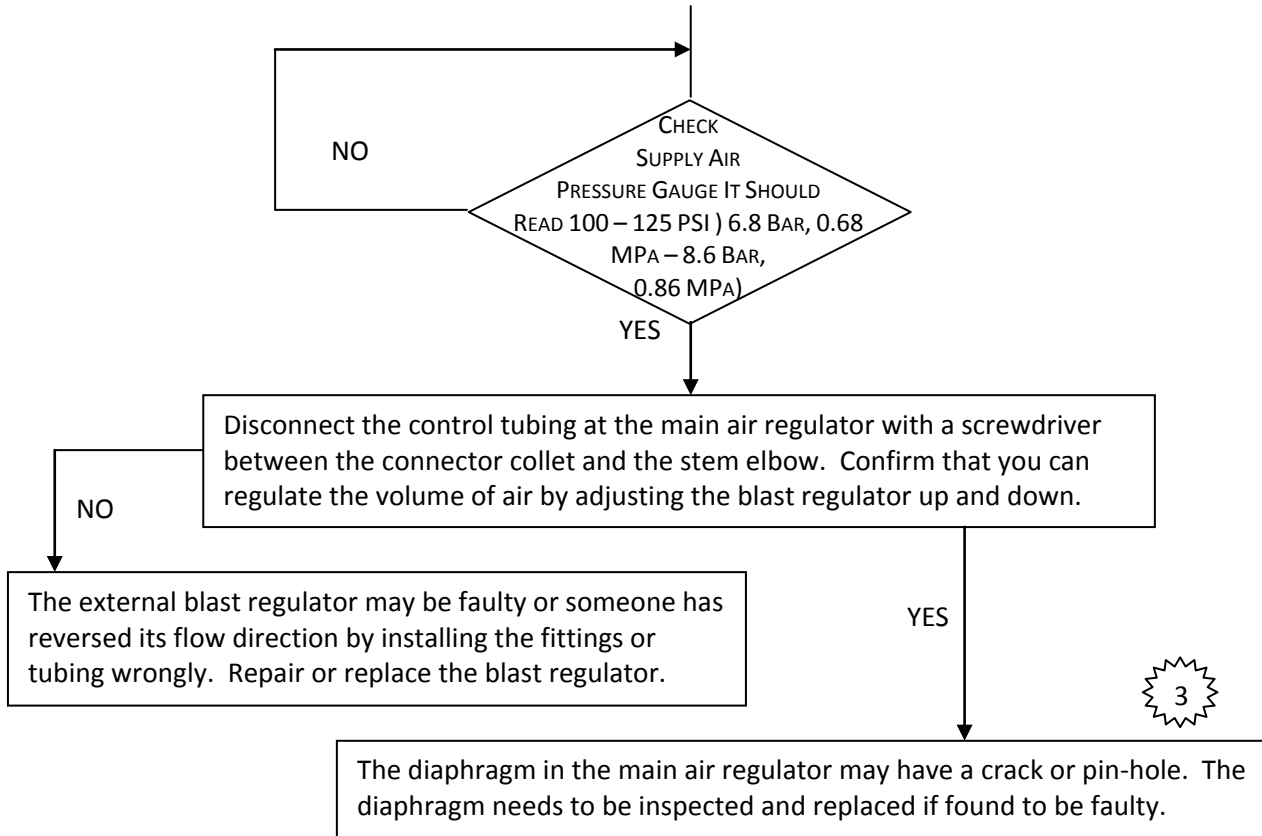

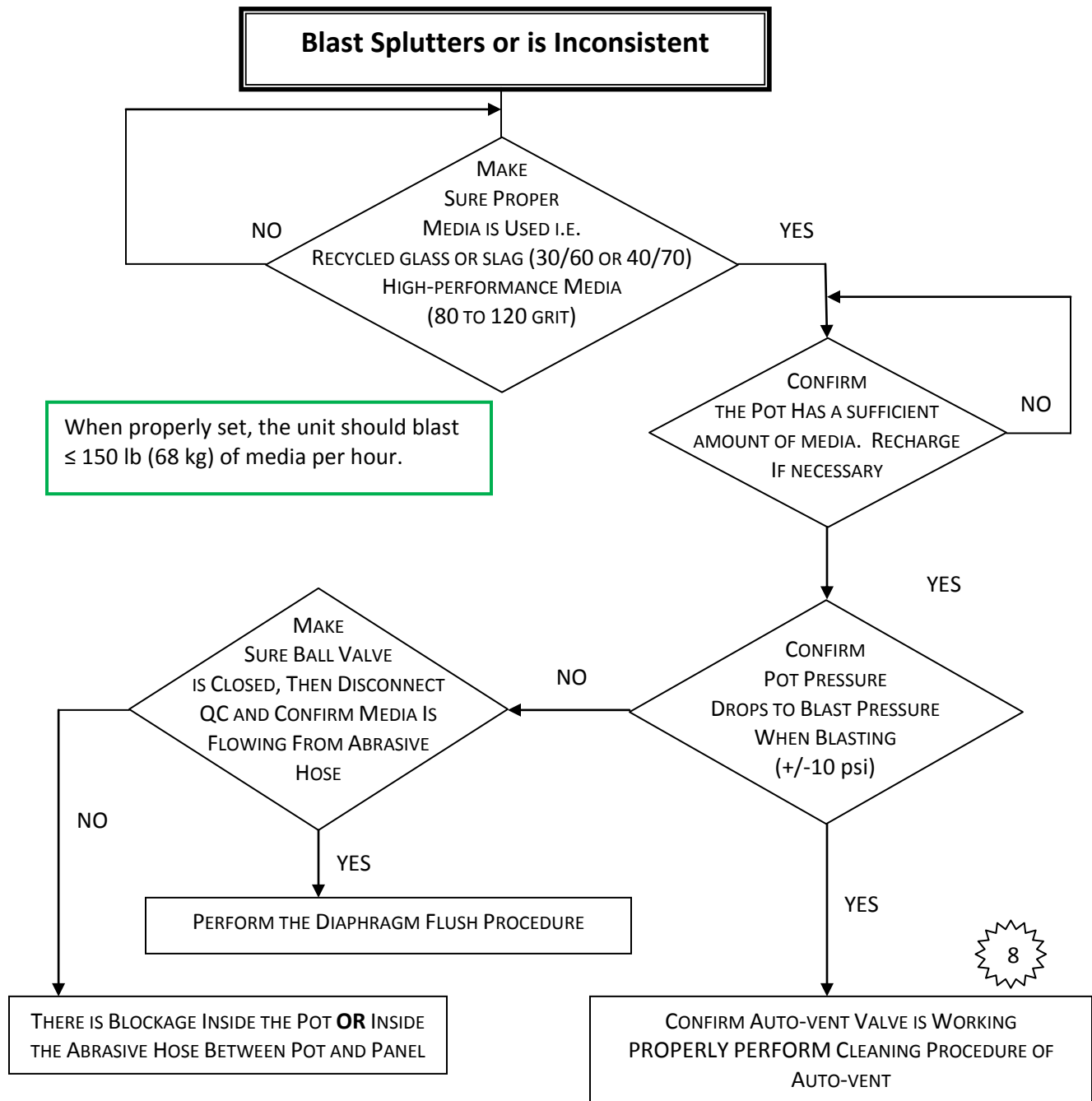

**Pot Pressure Drops Below Blast Pressure and Continues to Drop**

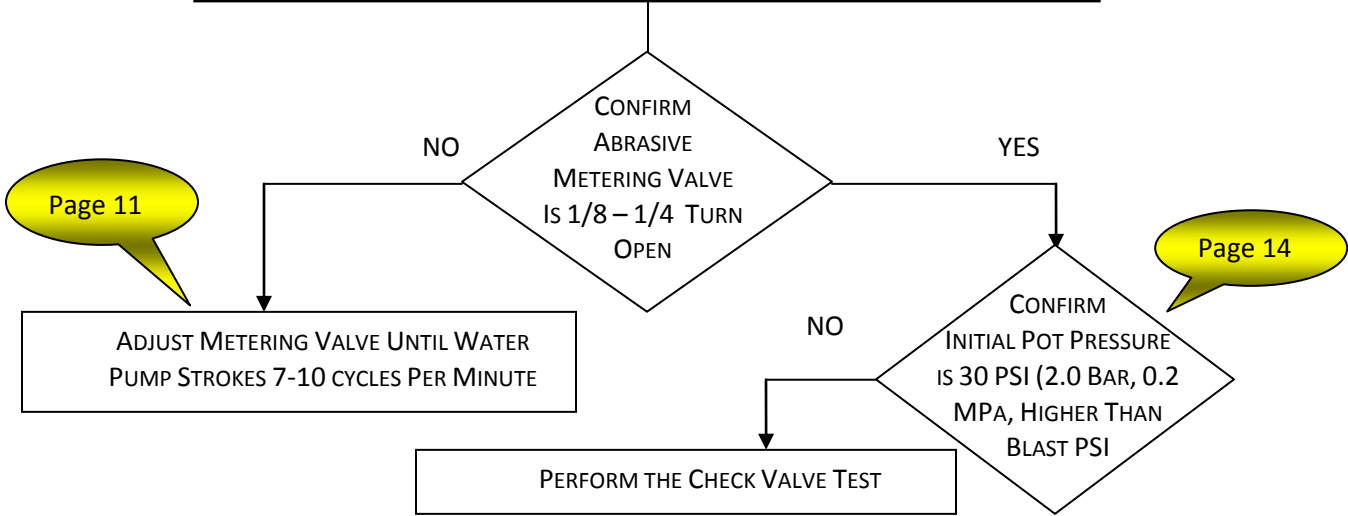

**“Water-hammer” Effect Every Time You Start Blasting**

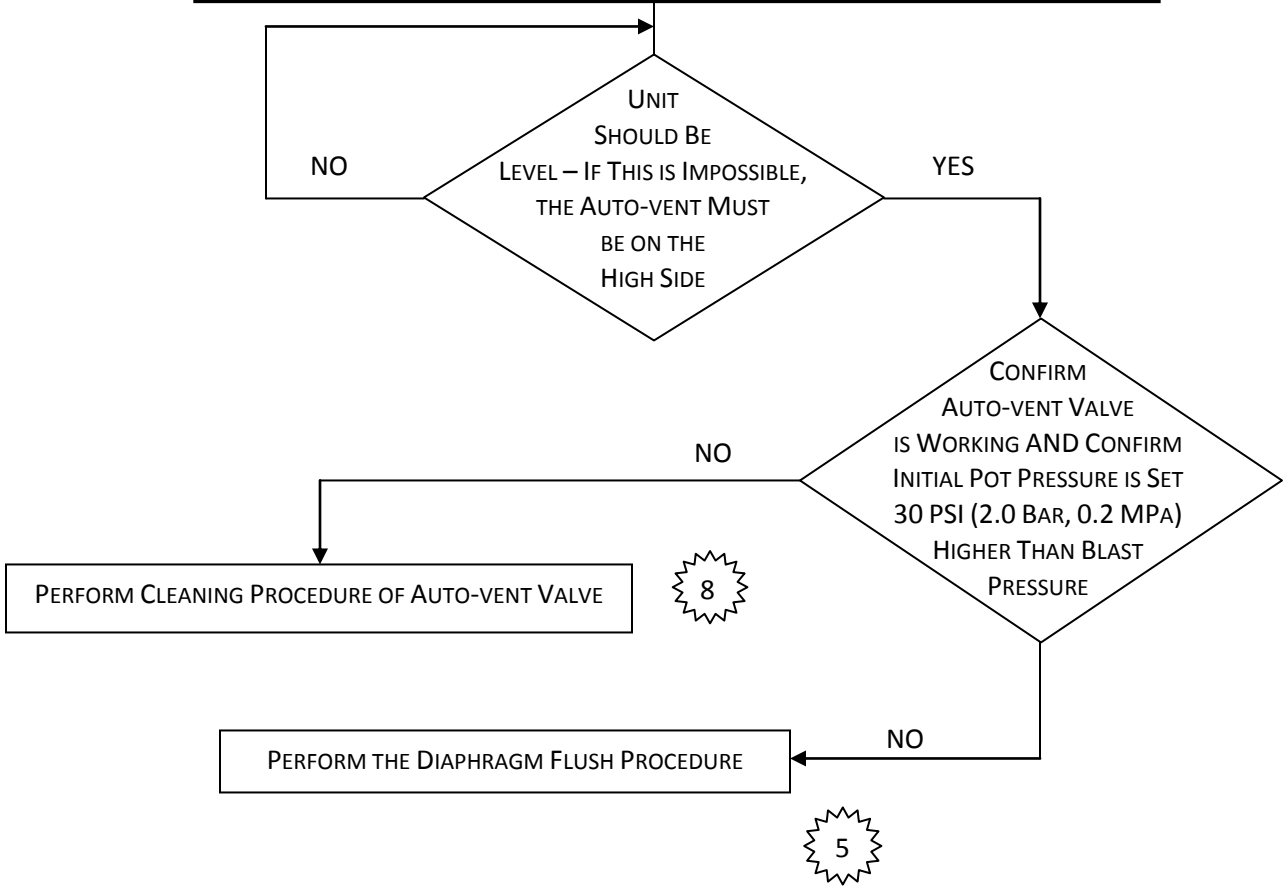

**No Blast, but Water Pump Runs When Dead Man is Engaged**

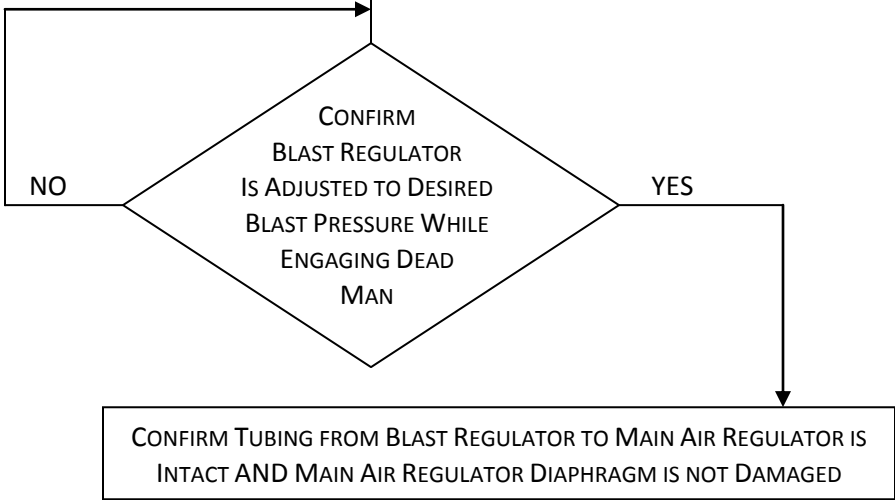

**Blast Happens Without Engaging Dead Man**

**Turn Off Air Supply Immediately and SECURE Blast Hose to Prevent Hose from Whipping**

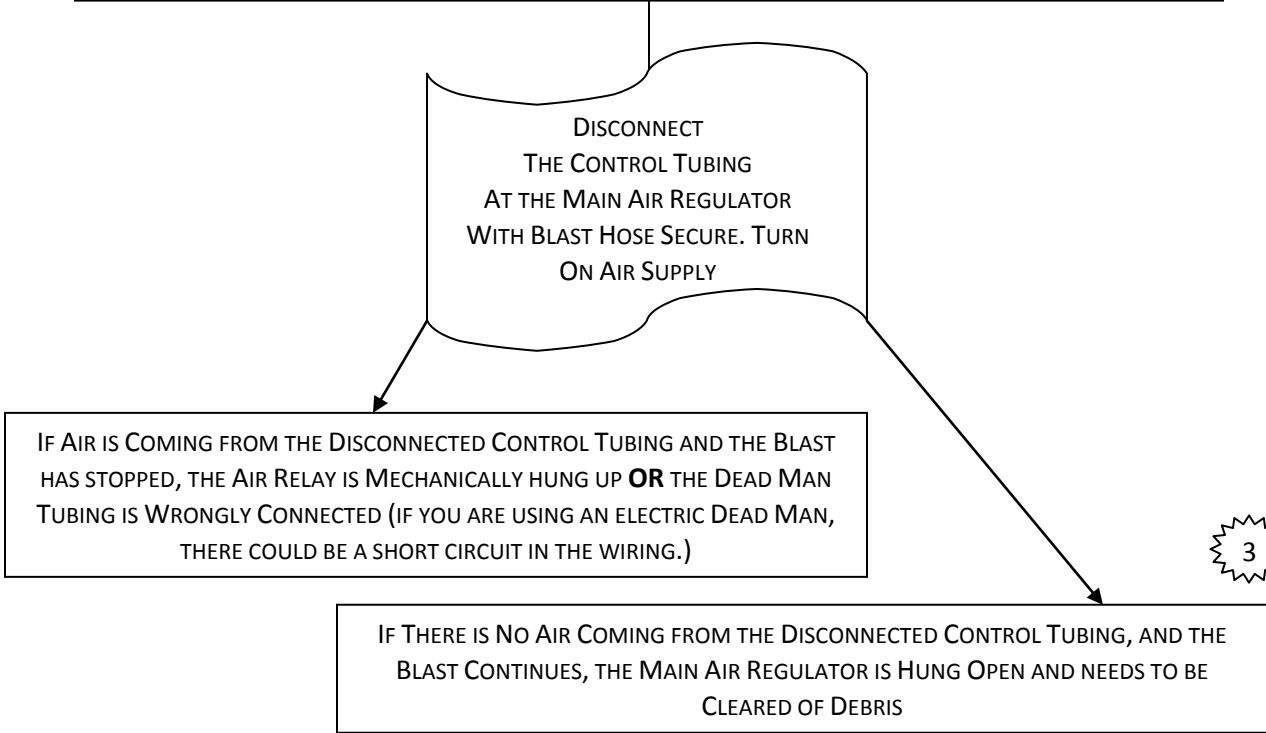

1

Examples given are for an Airman Compressor and Kaeser Compressor. Follow the instructions on the inside of the compressors to make sure that you are in the RUN mode for blasting.



For normal blasting temperature ranges, the lever should be in the horizontal (closed) position.



2

At the Air-Relay, disconnect the push-to-connect stem elbow. Use a flat-blade screwdriver to check the trigger circuit (from the pneumatic dead man handle). There is no need to pull the tubing out of the connector.

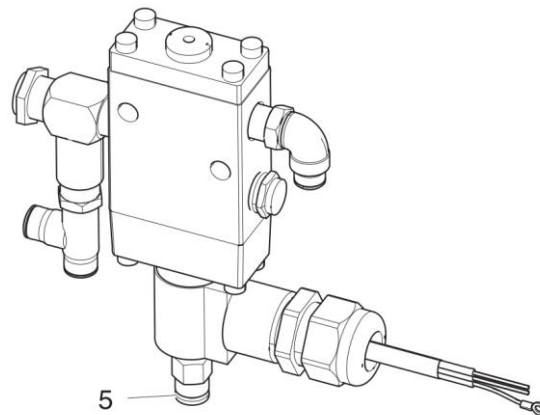

ti24447a

With the dead man switch activated, confirm that there is air flowing from the disconnected tube. The air flow should be at supply air pressure but the air volume is reduced due to the size of the fittings and tubing. If you do not get supply air force, check the dead man handle for proper operation, and check the dead man hoses to make sure they are not kinked or internally blocked (insect nests or other weird circumstances have happened), and check the in-line filter at the Industrial Interchange Nipple connection on the side of the panel (where you attach the dead man hose).

3

If the main air regulator does not operate (open) with air pressure applied to the diaphragm, it will have to be disassembled and thoroughly cleaned and the diaphragm will have to be checked for air leaks. This can be done with the main air regulator in the panel – there is no need to remove any plumbing.

Make sure all of the air pressure is relieved in the unit. Remove the water separator filter for access to the piston cover and return spring.

Unscrew the Piston Cover using a crescent that can open to 2 in. (5 cm) Be aware that there is a spring inside this cover.

Unscrew the diaphragm cover for access to the diaphragm and to the end of the piston shaft.

Remove the diaphragm and inspect for any cracks or tears.

Clean out any debris in the body of the regulator by carefully removing the spring and piston assembly.

Push the piston shaft and remove the piston from the opposite end of the regulator housing. Inspect for any foreign matter that may have been the cause for the piston to hang open. Inspect for any damage to the piston shaft where it interacts with the diaphragm cup. Excessive wear here indicates the main check valve is not sealing.

Perform the check valve flush procedure after replacing the worn components.

9

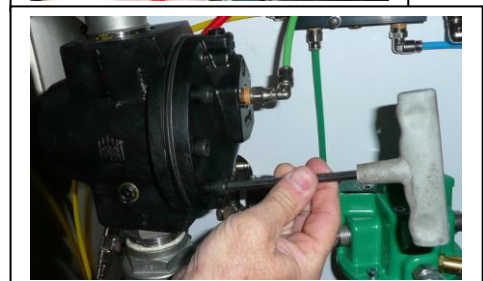
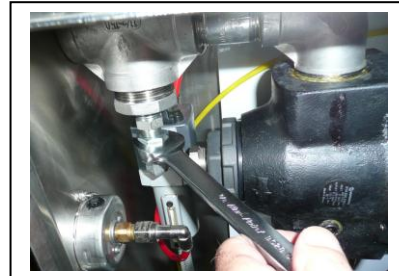

**4** This test can be performed with the component still mounted in the panel. Undo the tubing at the fitting of the regulator. (Note: This chamber is spring-loaded to keep the diaphragm closed). Air pressure greater than 80 psi (5.5 Bar, 0.55 MPa) pushes the Diaphragm Valve open. You should hear air from the disconnected tubing when you activate the dead man switch. Pop the plug at the end of the canister and insert a Sharpie® (or something similar) into the opening until it makes contact with the center bolt of the diaphragm. Reconnect the tubing and apply air pressure at the fitting and you should see the Sharpie® being pushed out, indicating that the valve opened. Release the air pressure and the Sharpie® should retract.



**5** This test can be performed with the component still mounted in the panel. Should large-grit media or other foreign matter become lodged in the diaphragm valve, it will become necessary to back-wash the valve. This is a simple procedure; however, it does cause the release of a huge volume of air to escape through the released quick coupling. **You need to be prepared for the release of air by pulling the quick coupler grommet out of its groove so that it does not get lost.**

1. Operate the unit in Wash Down until the media clears from the blast hose.
2. With the abrasive ball valve closed, position the selector valve to OFF.
3. Disconnect the Quick Coupling at the abrasive ball valve (NOT at the bottom of the pot).
4. Position the selector valve to the Wash Down position. This will pump water out of the quick coupler and allow you to reach up inside and clear all media and remove the grommet.
5. Making sure that nothing is in the path of the open quick coupler, engage the dead man handle – briefly and several times.
6. Anything that may have been stuck in the diaphragm valve should now have been cleared.
7. Hold the groove end of the quick coupler up to the water coming from the cam-lock end of the coupler to clean off any dirt or media.
8. Turn the selector valve to OFF to stop the flow of water.
9. Re-insert the grommet into its internal groove inside the cam-lock.
10. Reconnect the quick coupler – if properly clean and connected, there should be no leaks at the coupler during operation.

6

1. “Burp” the pot at the dump valve to release all of the pressure in the pot. Confirm by gauge.

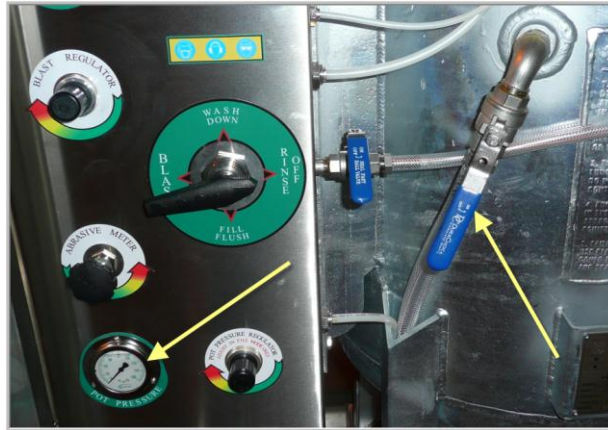

2. Disconnect the tubing at the flush check valve and at the fill port check valve.

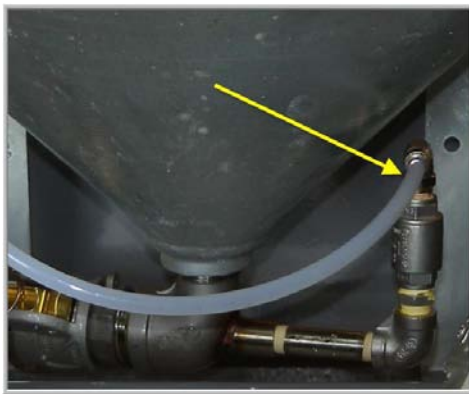

3. Make sure that the bung is engaged with its seal. Position the **Selector** in the **WASH DOWN** position and turn the abrasive hose ball valve to its **OPEN** position. Pressurize the **Pot**.

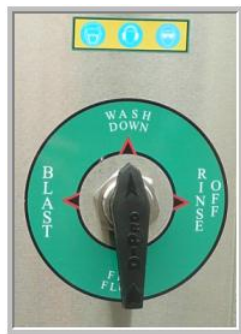

Check the water pump and confirm that no water is leaking from the weep-hole. Position the 3-way ball valve at the water tank with its handle pointing toward the open port. Water should initially flow (the water in the hose to the pump), but then the flow should stop. If the flow continues, the water pump lower seals are not holding and the pump lower-end needs repair.

4. Check for any water leaking from either check valve. If a check valve is leaking, it must be repaired or replaced – otherwise the pot will not be able to maintain its pressure.
5. Place the abrasive hose ball valve in its CLOSED position. Disconnect the quick coupler and confirm that the ball valve is not leaking.
6. Release the pressure in the pot before attempting repairs.

## Replacing the Diaphragm Valve Diaphragm

7

- 1) The diaphragm can be replaced without removing the assembly from the panel.
- 2) You will need an 8mm Allen wrench for the EQ600S and a 6mm for the EQ300S.
- 3) Make sure all of the pressure in the equipment has been properly released.
- 4) Loosen all 4 Allen-head cap-bolts evenly and then remove them completely while supporting the canister of the diaphragm valve.



- 5) Replace the diaphragm (natural rubber compound) and hand-tighten it as far as possible to establish the alignment with the canister. There are two shims between the diaphragm and the actuator – be careful to keep them, and reuse them as they do not come with the replacement diaphragm. **DO NOT** cause any pre-load or torque on the diaphragm by over-tightening it in a misaligned position.
- 6) Start all 4 Allen-head cap-bolts but do not tighten them.
- 7) Temporarily plumb a check-valve in-line with the diaphragm regulator.
- 8) Apply more than 80 psi (5.5 Bar, MPa) air pressure to the regulator inlet to cause the piston to retract. The check valve will hold the air in the diaphragm valve during installation. (An OSHA nozzle which has been set to 30 psi (2.0 Bar, 0.2 MPa) will not work, as it will not provide enough pressure to compress the springs.)
- 9) Hand-tighten the 4 Allen-head cap-bolts in an even pattern and then **release** the air pressure trapped by the check-valve.
- 10) Now tighten the cap-bolts, causing slight bulging of the diaphragm between the canister and the stainless steel casting.
- 11) Test and confirm that the unit is working properly. **NOTE:** This can be done using only water to charge the equipment – there is no need to use abrasive for this test.

8

During the process of filling the pot, AFTER the pop-up has been closed, the auto-vent valve **should** bleed air. (You should be able to hear the air venting.) The Pot Pressure Gauge will not show pressure until the auto-vent valve has bled all of the air and sealed. If the Auto-vent valve does not bleed air, or if water leaks from the stem during the fill process, the stem valve may be clogged or faulty. First try to push and quickly release the valve with your finger. If that does not cause the valve to seal, release all of the pressure in the pot and then force some water backwards into the valve stem using the rinse hose. (Selector valve needs to be in the Rinse/OFF position.) If that fails to resolve the issue, the valve assembly is faulty and needs to be replaced. The valve stem is internally attached to the float and it is **not** field-serviceable. Do not try to remove the valve stem.

Release all of the pressure in the pot BEFORE forcing water into the valve stem



9

Unscrew the fitting that attaches the separator filter to the main circuit plumbing. Remove the 3/8 in. hex nipple and insert a temporary 3/8 in. plug. Using a standard check valve and short piece of 1/4 in. tubing, apply air pressure to the diaphragm to hold the main air regulator in its open position.



Disconnect the air supply hose and the blast hose. Using a garden hose and a shop rag to help seal, force water into the air supply port. Water should flush out of the open blast hose port, clearing any media out of the check valve. Once the water pours cleanly, reverse the direction – force the water into the blast hose port. If water comes **out** of the air supply port, the check valve has **not** been cleared. Continue flushing until no water comes out of the air supply port when you reverse the water direction.

Remove the temporary plug, seal and reinstall the 3/8 in. hex nipple, and reinstall the water separator filter.

# Spare Parts Lists

Section 12.0

Main Blast Circuit Plumbing for:  
EQ600S

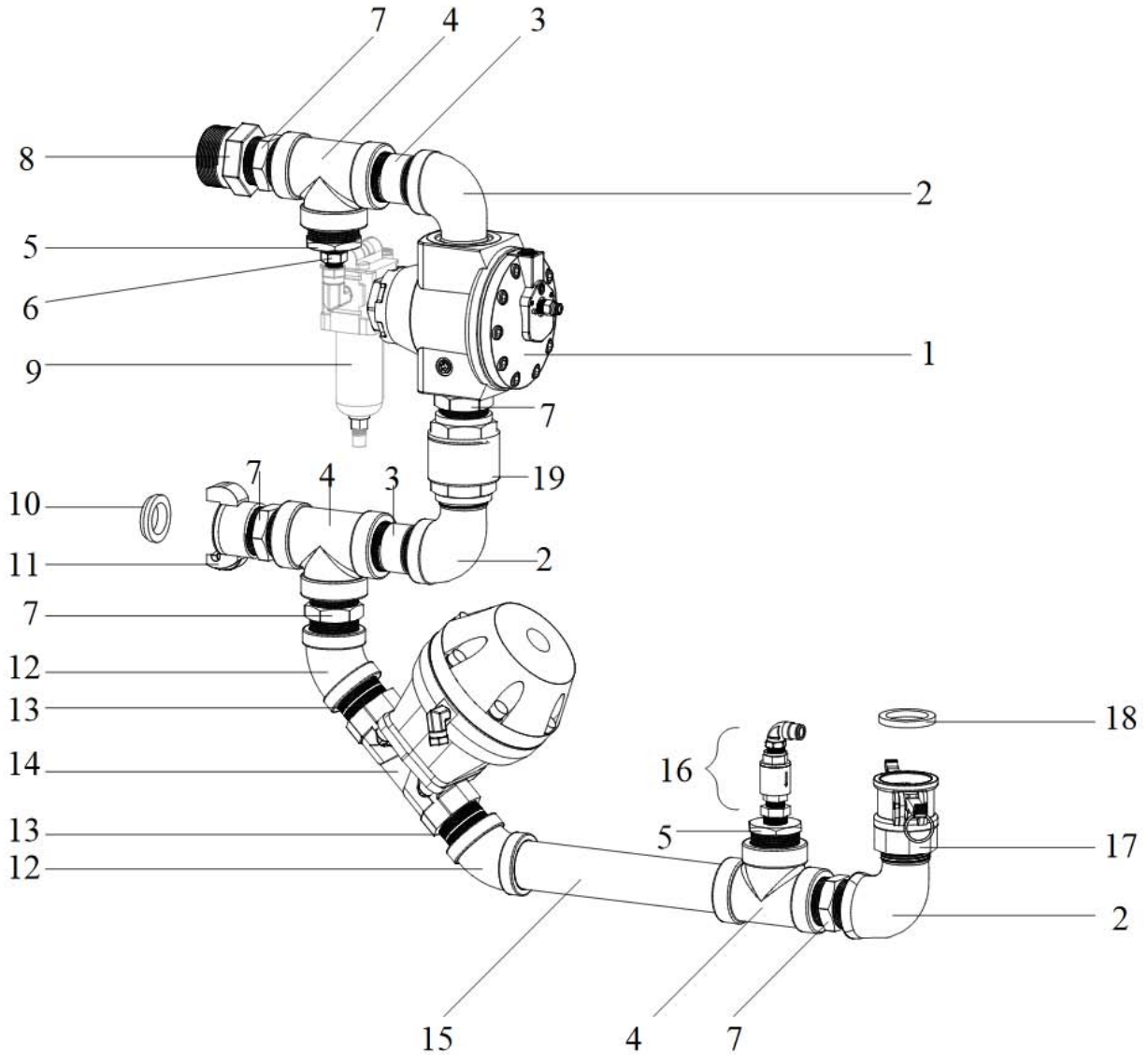

Components are numbered in a counter-clockwise order. Components that are part of a sub-assembly will be numbered together with their main component. The counter-clockwise order will resume after all the parts in the sub-assembly have been numbered. This should help you to identify the sub-assembly components more easily.

Main Blast Circuit Plumbing for:  
EQ600S

ITEM #	PART NUMBER	DESCRIPTION	QTY	NOTE
1	ASSY.40340770	AIR REGULATOR. MAIN 1-1/2 in.	1	NON-VENTED
*	48786636	1/4 x 1/4 Straight Connector	Incl.	
*	5890-52	Diaphragm Service Kit - R18 Regulator	AR	
2	PFT.EL.ST.150	ELBOW.STREET.90°.NPT.SS. 1-1/2 in.	3	
3	27-4T3-1/2	NIPPLE. 1-1/2 in. x 3-1/2 in. NPT	2	
4	PFT-TEE-150	TEE. 1-1/2 in. NPT	3	
5	PFT-HRB-150X050	BUSHING. HEX. 1-1/2 in. NPT	2	
6	5404-8-6	NIPPLE. HEX. REDUCER. ½ in. x 3/8 in.	1	
7	PFT.NH.150	NIPPLE. HEX. 1-1/2 in. 316 SS	5	
8	GB23	GROUND JOINT. BOSS. 1-1/2 in. FPT	1	
9	See Page 48	AIR FILTER ASSY WITH FITTINGS	1	
10	SBG-URE	GASKET. SB. TANK COUPLER	AR	Included in #11
11	BSC150	COUPLER. SANDBLAST. TANK. BRASS. 1-1/2 in. FPT	1	
12	PFT.EL.45°.150	ELBOW. 1-1/2 in. 45°. NPT	2	
13	27-4T1-3/4	NIPPLE. CLOSE 1-1/2 in.	2	
14	ASSY.GEMU. 1-1/2 in.	GEMU ASSY. 1-1/2 in.	1	Includes #(14)
(14)	1501-4-4	ELBOW. SWIVEL. ¼ in. FNPSM X ¼ in. MPT	Incl.	
*	2101324-600040M25 600M	DIAPHRAGM. CODE 25. 1-1/2 in.	AR	Replacement diaphragm
15	27-4T11	NIPPLE. 1-1/2 in. x 11 in.	1	
16	See Page 56	WASH CHECK VALVE ASSY	1	
17	150-D-SS	CAMLOCK. 1-1/2 in. FPT	1	
18	150-G-BU	GASKET. CAMLOCK. 1-1/2 in. BUMA	AR	
19	VCSL1-150	VALVE. CHECK. 1-1/2 in. FPT SS316	1	

Main Blast Circuit Plumbing for:  
EQ300S

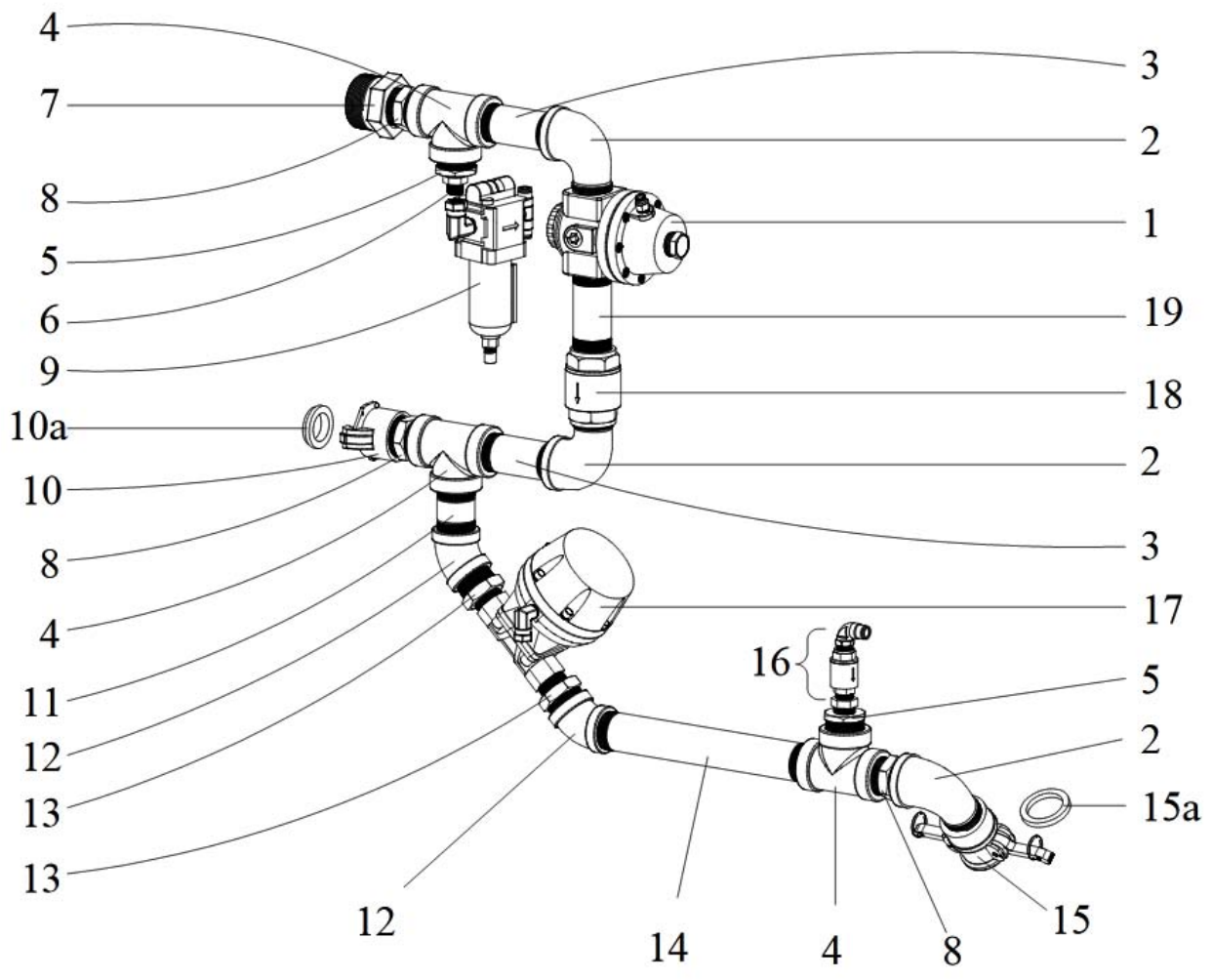

Main Blast Circuit Plumbing for:  
EQ300S

ITEM #	PART NUMBER	DESCRIPTION	QTY	NOTE
1	ASSY.01724772	REGULATOR. 1-1/4 in. PILOT ASSY	1	
*	4158-02	REPAIR KIT. MAJOR. NORGREN 11-042-008/009 MAIN AIR REGULATORS	AR	
2	PFT.EL.ST.125	ELBOW.STREET.90°.NPT.SS. 1-1/4 in.	3	
3	27-4S3	NIPPLE.NPT.SS. 1-1/4 in. X 3 in.	3	
4	PFT-TEE-125	TEE.FPT.SS. 1-1/4 in.	3	
5	PFT-HRB-125X050	BUSHING.HEX REDUCER.NPT.SS. 1-1/4 in. x ½ in.	2	
6	5404-8-6	NIPPLE. HEX. REDUCER, ½ in. x 3/8 in.	1	
7	GB18	GROUND JOINT. BOSS. 1-1/4 in. FPT	1	
8	PFT.NH.125	NIPPLE.HEX.NPT.SS. 1-1/4 in.	3	
9	See Page 48	Filter. Assy.	1	
10	BSC-125	COUPLING. BRASS SAND BLAST TANK. 1-1/4 in. FPT	1	
10a	SBG-URE	GASKET. SB. TANK COUPLER	AR	
11	27-4S2-1/2	NIPPLE.NPT.SS. 1-1/4 in. X 2-1/2 in.	1	
12	PFT.EL.45°.125	ELBOW.45°.SS. 1-1/4 in.	2	
13	PFT-HRB-125X100	BUSHING.HEX REDUCER.NPT.SS. 1-1/4 in. x 1 in.	2	
14	27-4S11-1/2	NIPPLE.NPT.SS. 1-1/4 in. X 11-1/2 in.	1	
15	125-D-SS	CAM.LOCK.TYPE D.SS. 1-1/4 in. FPT	1	
15a	150-G-BU	GASKET. CAMLOCK. 1-1/2 in. BUMA	AR	
16	See Page 57	Wash down Check Valve Assy.		
17	ASSY.GEMU. 1 in.	GEMU ASSY. 1 in.	1	
(17)	1501-4-4	MPT to FNPSM Swivel 90* elbow	Incl.	
*	2101323- 600025M25 600M	DIAPHRAGM. CODE 25. ½ in. – 1 in.	AR	Replacement diaphragm
18	VCSL1-125	VALVE. CHECK. 1-1/4 in. FPT SS316	1	
19	27-4S5-1/2	NIPPLE.NPT.SS. 1-1/4 in. X 5-1/2 in.	1	
NS	05666979	WASHER. SHIM. SS. 2.005 ID X 2.750 OD X .090 T	AR	

# Air Control Components All Models

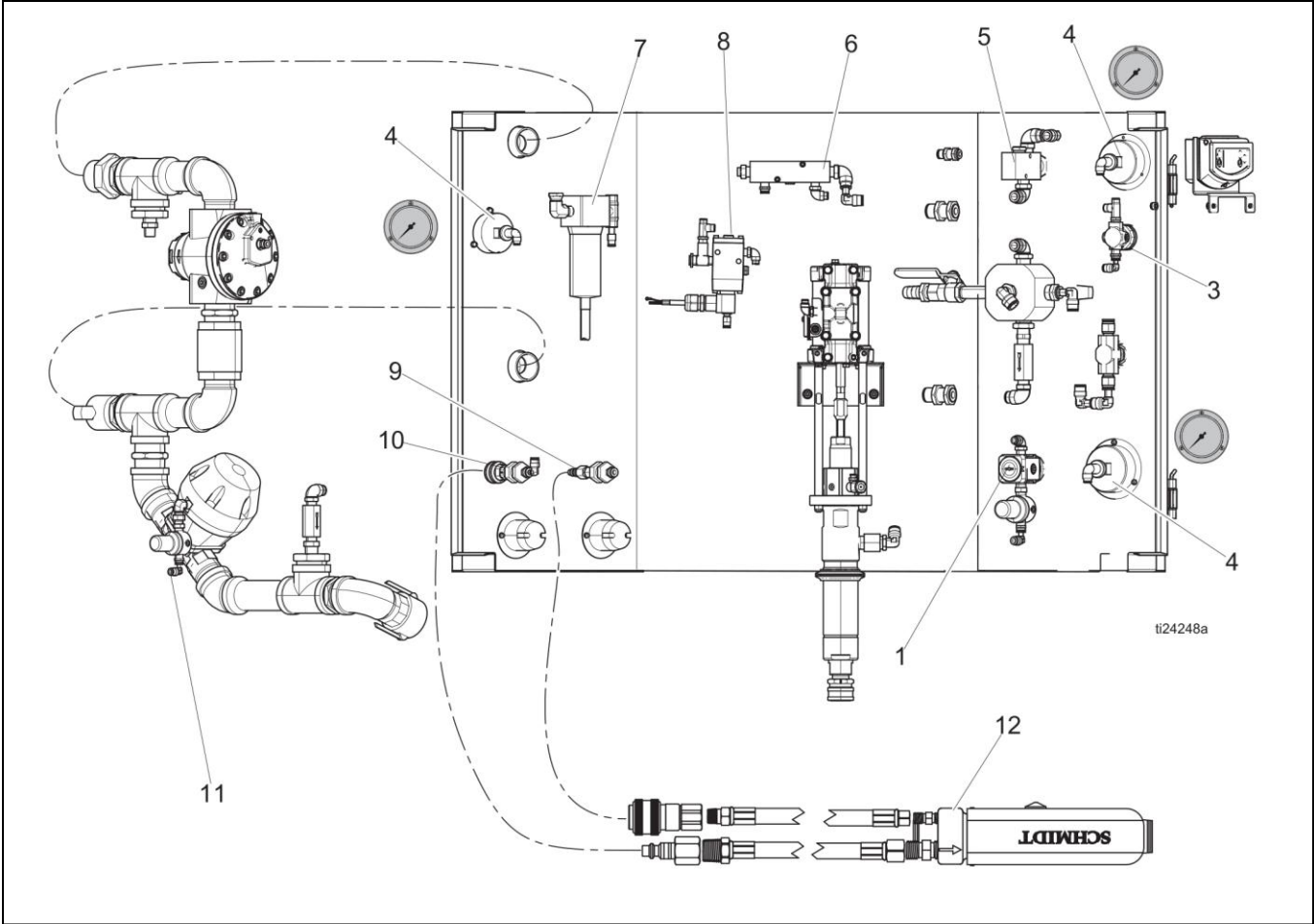

ITEM	PART NUMBER	DESCRIPTION	QTY	NOTES
1	EQ5104	REGULATOR, pump	1	See Page 43
3	EQ5157	REGULATOR, assembly, blast, 0-125	1	See Page 44
4	EQ5107	KIT, gauge and fitting	3	See Page 45
5	EQ5108	KIT, E-stop, 3/8 npt	1	See Page 46
6	EQ5109	KIT, manifold	1	See Page 47
7	EQ5110	KIT, air filter, 3/8 tube	1	See Page 48
8	EQ5179	RELAY, air pilot, deadman	1	See Page 49
9	EQ5112	KIT, deadman, return	1	See Page 50
10	EQ5113	KIT, deadman, output	1	See Page 50
11	EQ5119	REGULATOR, fixed, 80 psi	1	See Page 51
12		HOSE and ASSEMBLY, deadman	1	See Page 54

Air Control Sub-assemblies: 1  
Pump Regulator

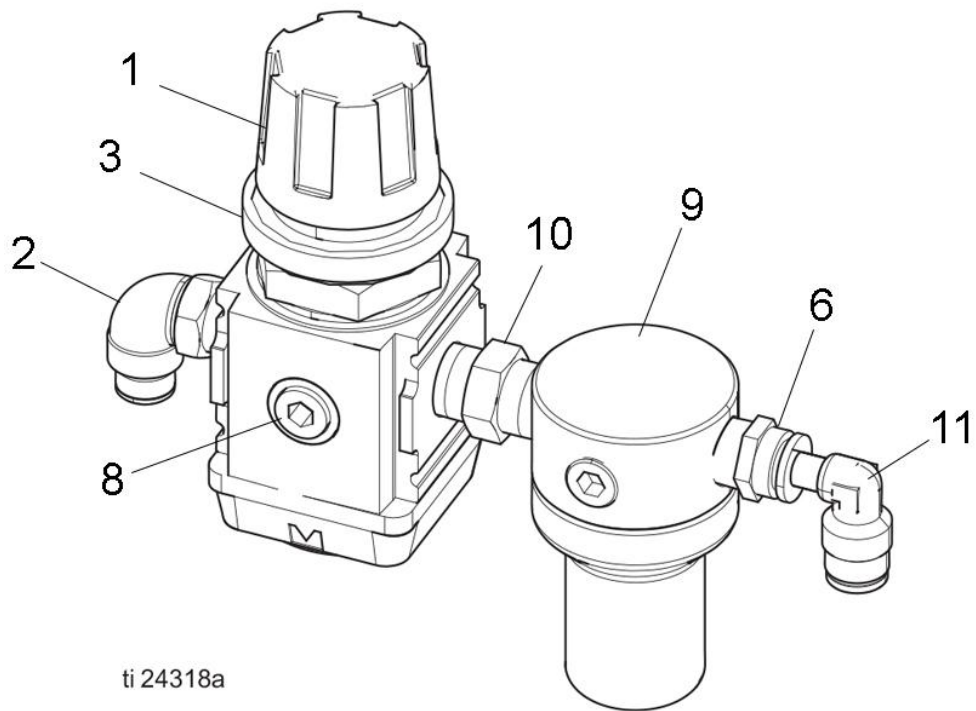

ti 24318a

**EQ5104**

ITEM	PART NUMBER	DESCRIPTION	QTY
1	120432	REGULATOR, panel, mount	1
2	121022	FITTING, elbow, male, ¼ npt	1
3	EQ1066	RING, panel mounting, 1-1/8 in.	1
6	C19407	FITTING, connector, male	1
8	100139	PLUG, pipe	1
9	EQ1395	REGULATOR, fixed air, 80 psi	1
10	156971	FITTING, nipple, short	1
11	EQ1121	FITTING, elbow, stem, ¼ in.	1

Air Control Sub-assemblies: 3  
Blast Regulator

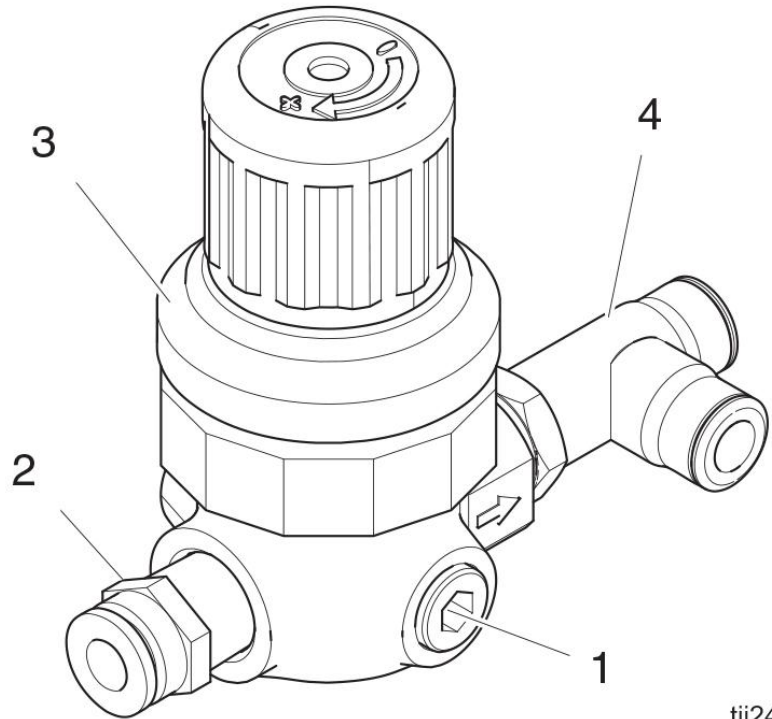

tii24434a

**EQ5157**

ITEM	PART NUMBER	DESCRIPTION	QTY	NOTES
1	EQ1393	REGULATOR, air, 0-125 psi	1	
2	C19407	FITTING, connector, male	1	
3	EQ1066	RING, panel mounting, 1-1/8 in.	1	
4	125733	FITTING, tee, 1/4 in. tube x 1/4 npt	1	

**Air Control Sub-assemblies: 4**  
**Gauge and Fitting**

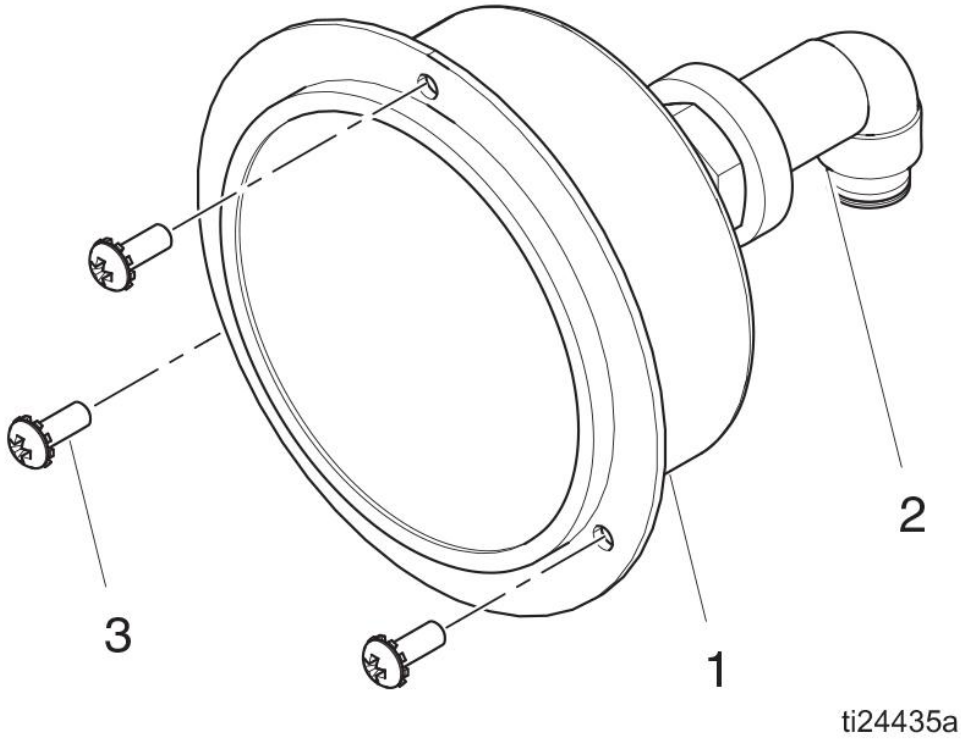

ti24435a

**EQ5107**

ITEM	PART NUMBER	DESCRIPTION	QTY
1	EQ1132	GAUGE, flange mount, 2-1/2 in.	1
2	EQ1113	FITTING, elbow, swivel, female	1
3	127929	SCREW	1

Air Control Sub-assemblies: 5  
E-Stop

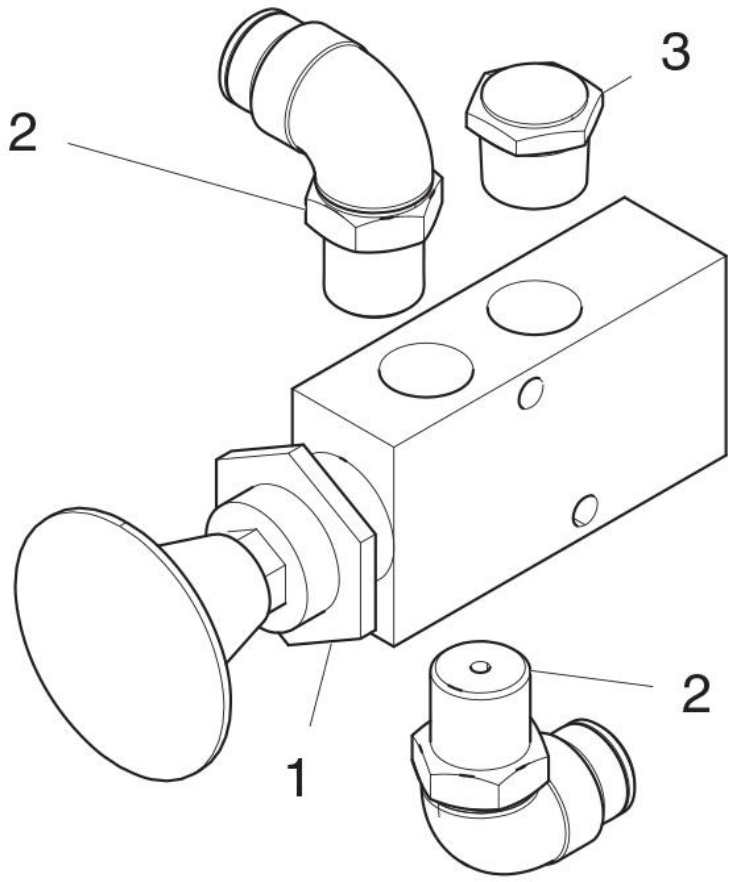

ti24436a

**EQ5108**

ITEM	PART NUMBER	DESCRIPTION	QTY
1	EQ1408	VALVE, 3-way, E-stop, 3/8 in. fpt	1
2	EQ1500	FITTING, elbow, swivel, male, 3/8 in.	2
3	EQ1438	VENT, breather, 3/8 in.	1

Air Control Sub-assemblies: 6  
Manifold

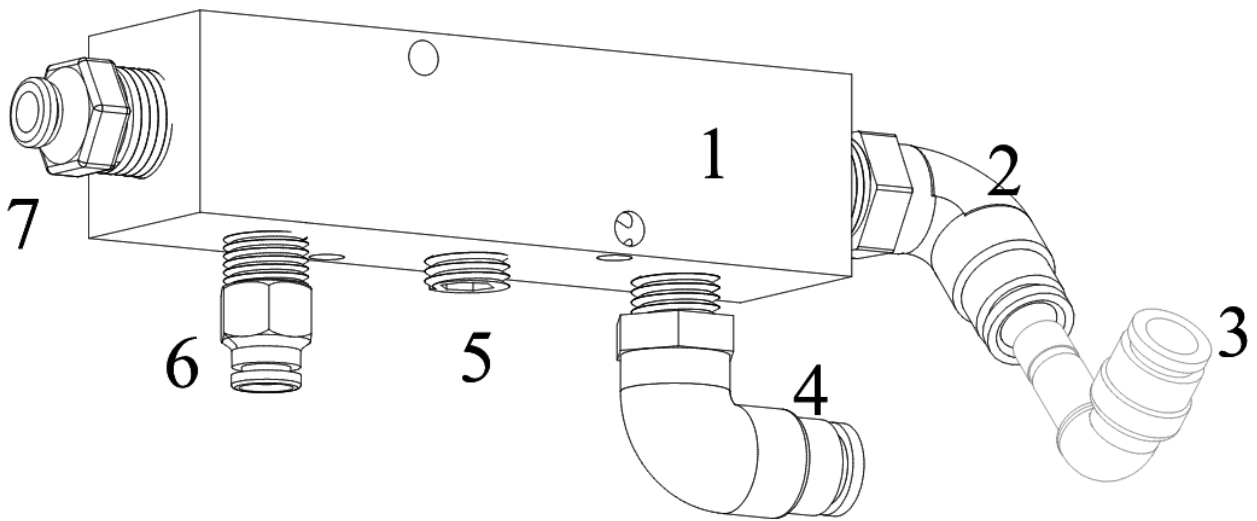

**EQ5109**

ITEM	PART NUMBER	DESCRIPTION	QTY
1	EQ1197	MANIFOLD, 3-port, w/2 input	1
2	C19407	FITTING, connector, male	1
3	100721	PLUG, pipe	1
4	121022	FITTING, elbow, male, ¼ npt	1
5	EQ1500	FITTING, elbow, swivel, male 3/8 in.	1
6	EQ1834	FITTING, connector, straight male	1

**Air Control Sub-assemblies: 7**  
**Air Filter**

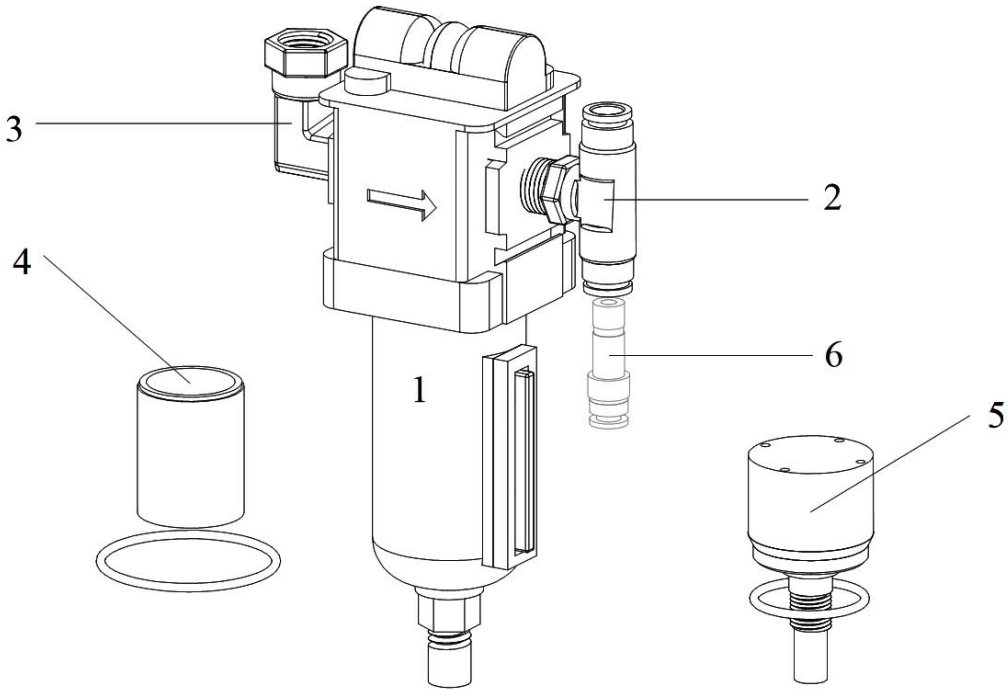

**55110**

ITEM	PART NUMBER	DESCRIPTION	QTY	NOTES
	<b>ASSY.P32FA93FSAN</b>	<b>AIR FILTER ASSY WITH FITTINGS</b>		
1	P32FA93FSAN	FILTER. AIR. 3/8 in. FPT w/DPI	1	
2	48789879	TEE. BRANCH. SWIVEL MALE. 3/8 in. x 3/8 in.	1	
3	1501-6-6	ELBOW. SWIVEL. 3/8 in. FNPSM X 3/8 in. MPT	1	
4	P32KA00ESE	ELEMENT. REPLACEMENT. FOR P32FA93FSAN	AR	
5	P32KA00DA	KIT. REPAIR AUTO-DRAIN	AR	
6	6800 04-06	STEM.REDUCER. 1/4 in. X 3/8 in.	AR	Not included
NS	K3150-05	HOSE.CLEAR.BRAIDED. 5/16 in. I.D.	AR	

**Air Control Sub-assemblies: 8**  
**Air Pilot**

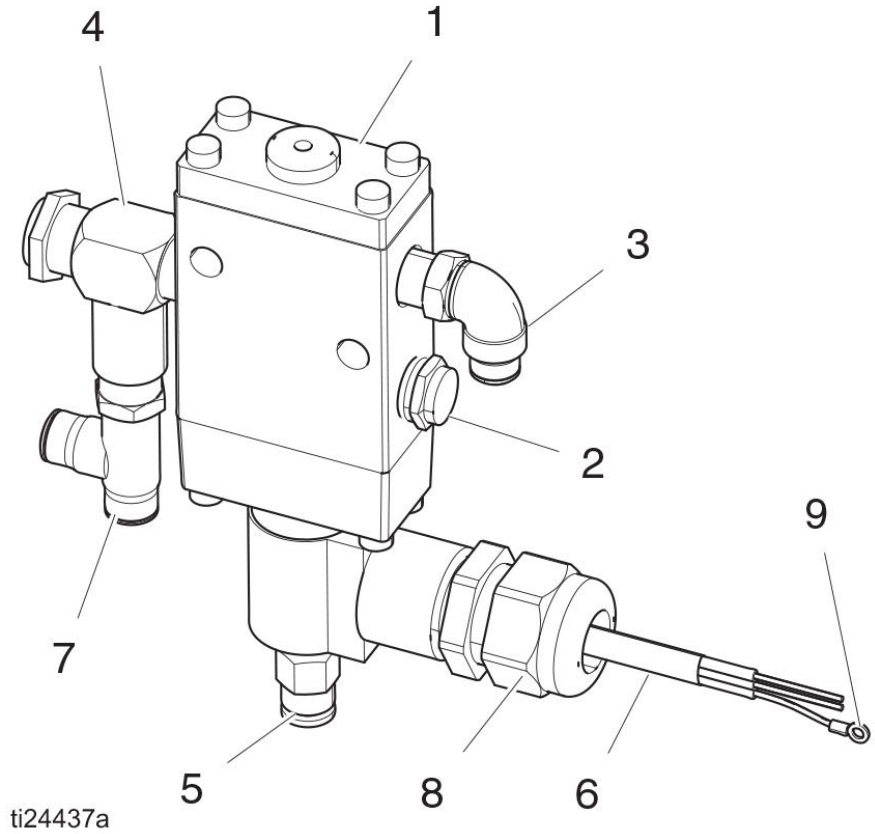

**EQ5179**

ITEM	PART NUMBER	DESCRIPTION	QTY
1	EQ1405	VALVE, 3-way, solenoid, air pilot	1
2	121021	MUFFLER, ¼ npt	1
3	121022	FITTING, elbow, male, ¼ npt	1
4	EQ1440	VALVE, adjustable flow, ¼ (f)	1
5	114332	FITTING, connector, male	1
6	070706	TUBE, polyolefin, shrink, yellow	1
7	125733	FITTING, tee, ¼ tube x ¼ npt	1
8	117745	BUSHING, strain relief	1
9	EQ7143	TERMINAL, ring, crimp-on, insulated	1

**Air Control Sub-assemblies: 9&10  
Remote Switch Return**

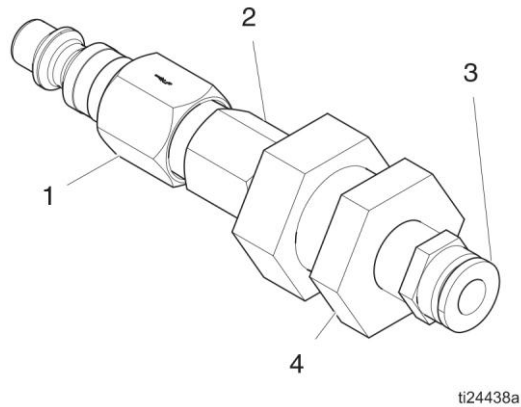

**EQ5112**

ITEM	PART NUMBER	DESCRIPTION	QTY
1	EQ1421	FITTING, nipple, industrial interchange	1
2	EQ1814	FILTER, inline, 1/4 in. mpt	1
3	C19407	FITTING, connector, male	1
4	123390	FITTING, 1/4 npt, brs	1

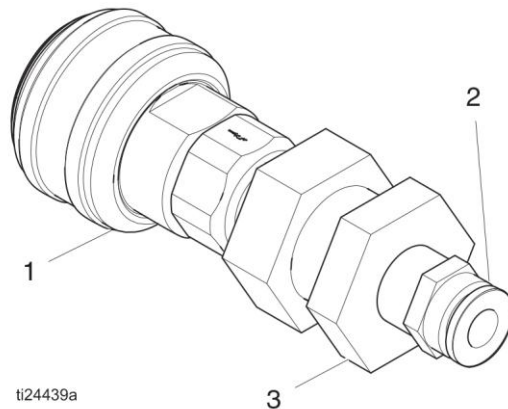

**EQ5113**

ITEM	PART NUMBER	DESCRIPTION	QTY
1	EQ1813	COUPLER, industrial interchange	1
2	C19407	FITTING, connector, male	1
3	123390	FITTING, 1/4 npt, brs	1

Air Control Sub-assemblies: 11  
Regulator

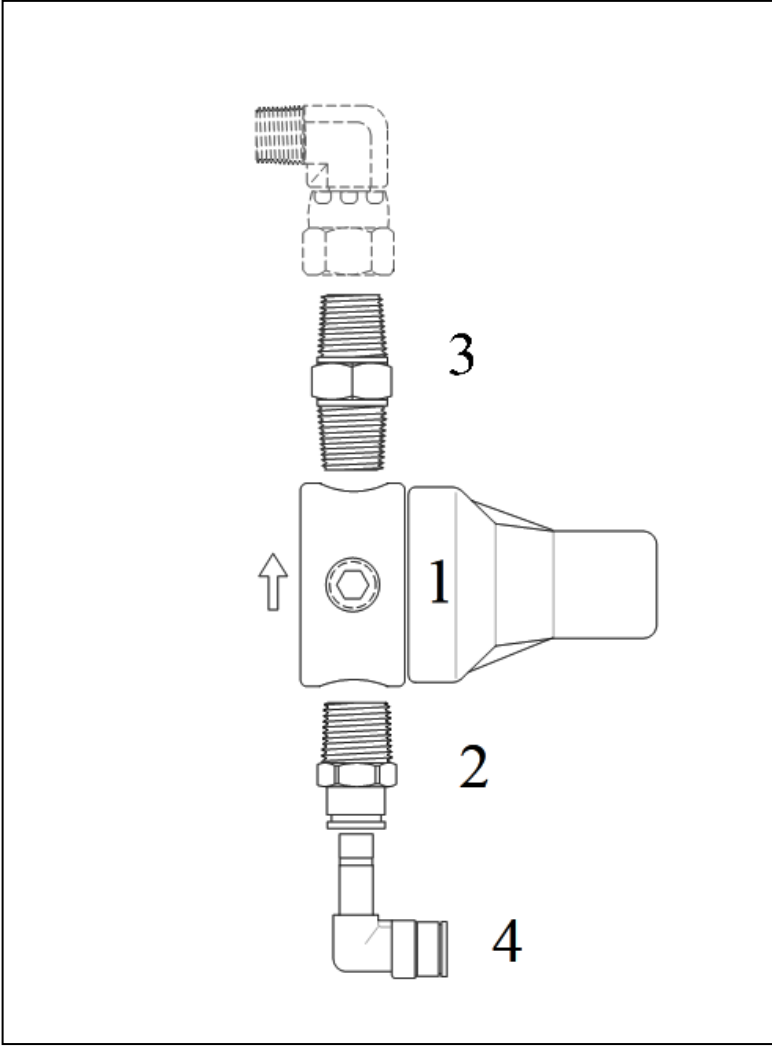

**55119**

ITEM	PART NUMBER	DESCRIPTION	QTY	NOTES
	<b>ASSY.62629092</b>	FIXED REGULATOR ASSY FOR GEMU. 80 psi		
1	62629092	REGULATOR. FIXED AIR. 80 psi	1	
2	48786636	ADAPTER.STRAIGHT. 1/4 in. x 1/4 in.	1	
3	5404-4	NIPPLE. 1/4 in. MPT	1	
4	6555 04-04	ELBOW. STEM. 1/4 in.	AR	Not included
	1501-4-4	MPT to FNPSM Swivel 90° elbow		See Page 38

## Air Control Sub-assemblies: 12

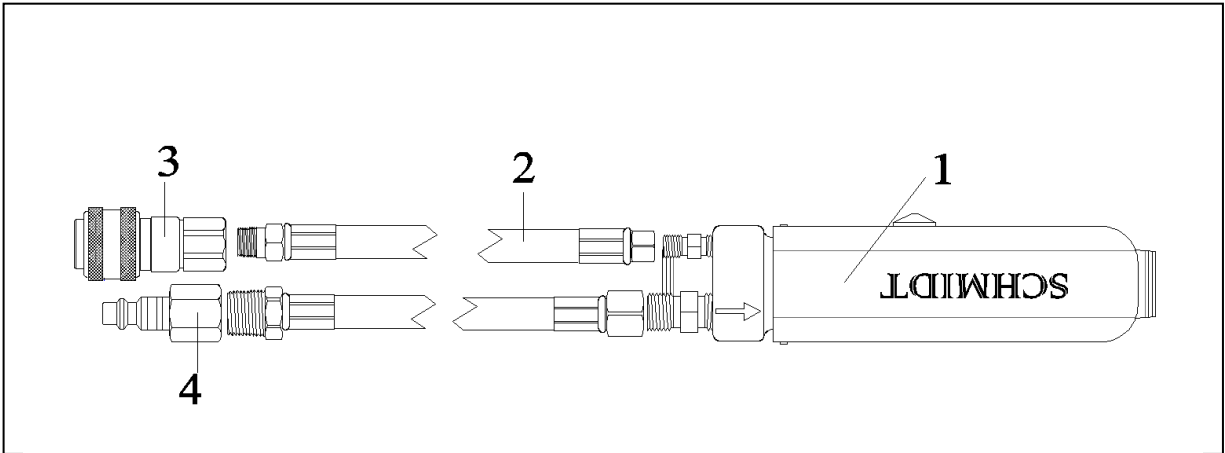

### 55188

ITEM	PART NUMBER	DESCRIPTION	QTY	NOTES
1	2263-002	DEADMAN. PNEUMATIC. G2	1	
2	DMA-PB-050	PNEUMATIC TWINLINE. 52 ft for BLAST HOSE ASSY	1	Includes 2,3,4
3	2DF1-B	COUPLER. INDUSTRIAL INTERCHANGE. 1/8 in. FPT	1	
4	D2F2-B	NIPPLE. INDUSTRIAL INTERCHANGE. 1/4 in. FPT	1	

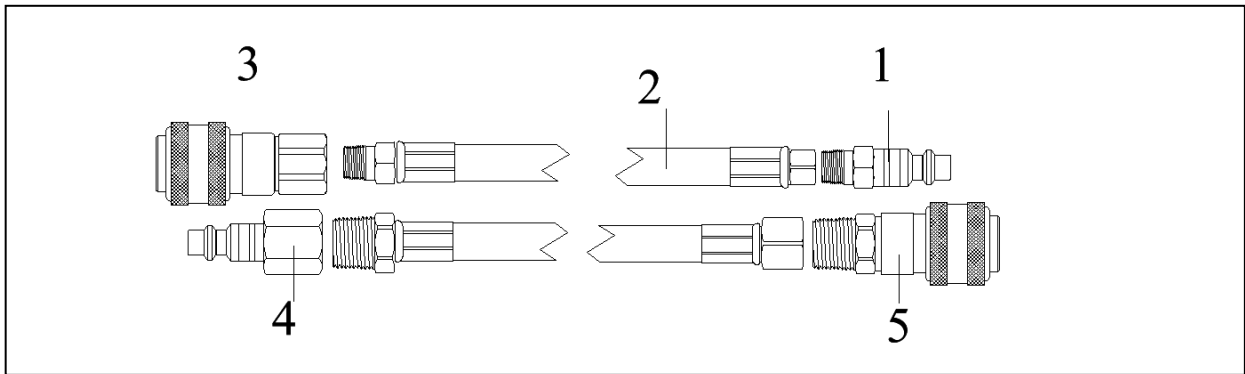

### 55075 (50ft)      55079 (100ft)

ITEM	PART NUMBER	DESCRIPTION	QTY	NOTES
1	D2M1-B	NIPPLE. INDUSTRIAL INTERCHANGE. 1/8 in. MPT	1	option
Assy.	DMA-PX-050	PNEUMATIC TWINLINE. 52 ft for EXTENSION ASSY	1	Includes 1-5
Assy.	DMA-PX-100	PNEUMATIC TWINLINE. 102 ft for EXTENSION ASSY		Includes 1-5
3	2DF1-B	COUPLER. INDUSTRIAL INTERCHANGE. 1/8 in. FPT	1	option
4	D2F2-B	NIPPLE. INDUSTRIAL INTERCHANGE. 1/4 in. FPT	1	option
5	2DM2-B	COUPLER. INDUSTRIAL INTERCHANGE. 1/4 in. MPT	1	option

# Air Control Tubing All Models

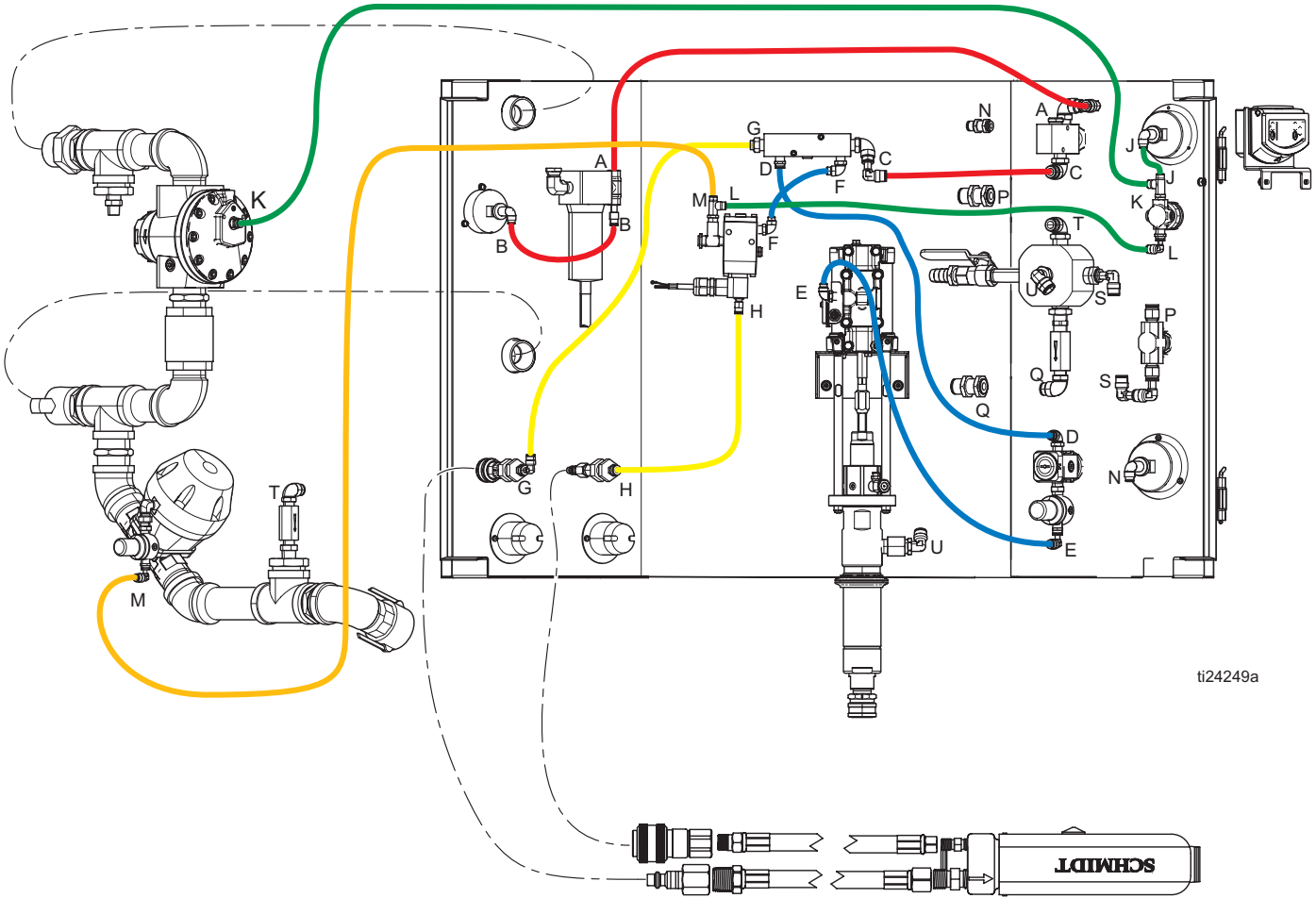

ti24249a

# Blast Hose Components

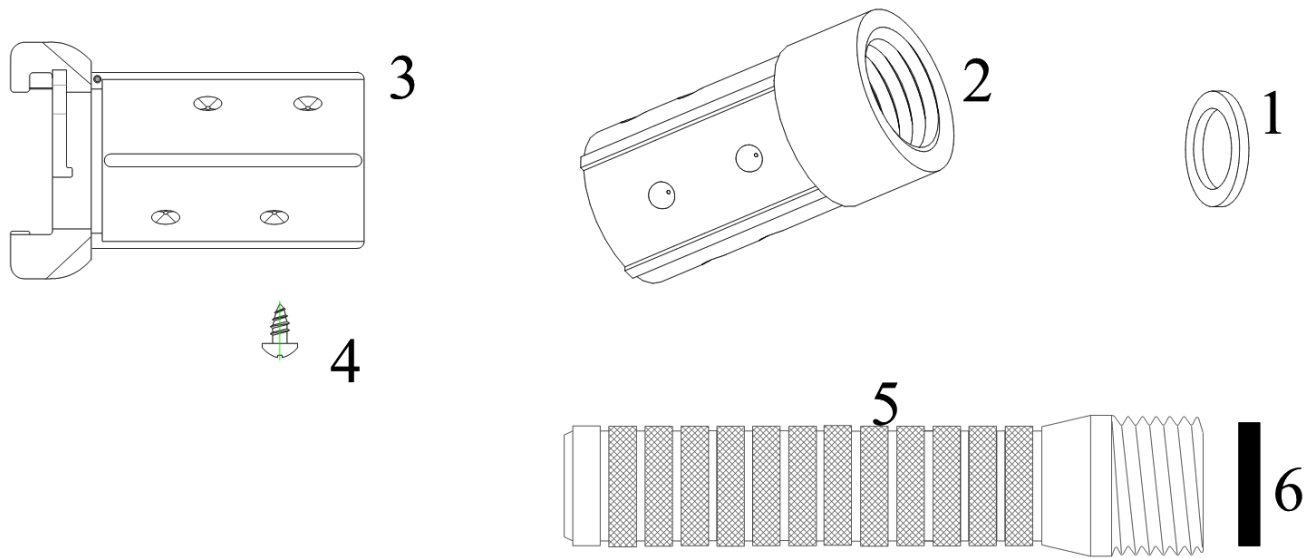

ITEM	PART NUMBER	DESCRIPTION	QTY	NOTES
	BHAP-125-050	HOSE. BLAST. 2-PLY. PNEUMATIC. 1.25 in. I.D. X 50 ft	AR	EQ600S – PNEUMATIC DM
	BHAE-125-050	HOSE. BLAST. 2-PLY. ELECTRIC. 1.25 in. I.D. X 50 ft	AR	EQ600S – ELECTRIC DM
1	NW-50MM	GASKET. NOZZLE HOLDER, 1.734 in. O.D. x 1-1/4 in. I.D.	AR	Replacement, same as #6
2	MHE2-NY-O	NOZZLE HOLDER. SANDBLAST. NYLON. CONTRACTOR THREAD. ORANGE. 1-7/8 in. O.D. HOSE	AR	EQ600S
2	MHE2-NY-Y	NOZZLE HOLDER. SANDBLAST. NYLON. CONTRACTOR THREAD. YELLOW. 1-7/8 in. O.D. HOSE	AR	EQ300S
3	Q2-NY-O	COUPLING. SANDBLAST. NYLON. ORANGE. 1-7/8 in. O.D. HOSE	AR	EQ600S
3	Q2-NY-Y	COUPLING. SANDBLAST. NYLON. YELLOW. 1-7/8 in. O.D. HOSE	AR	EQ300S
4	87923256	SCREW. SHEET METAL. PHPH. SS. #10 X 1/2 in.	AR	ALL
5	SICWA-8/50HD	NOZZLE. BLAST. #8. SILICON CARBIDE WIDE ENTRY. IMPACT RESISTANT	AR	EQ600S
5	SICWA-7/50HD	NOZZLE. BLAST. #7. SILICON CARBIDE WIDE ENTRY. IMPACT RESISTANT	AR	EQ300S
6	NW-50MM	GASKET. NOZZLE HOLDER, 1.734 in. O.D. x 1-1/4 in. I.D.	AR	Included with new nozzle

## Electric Components and Connections

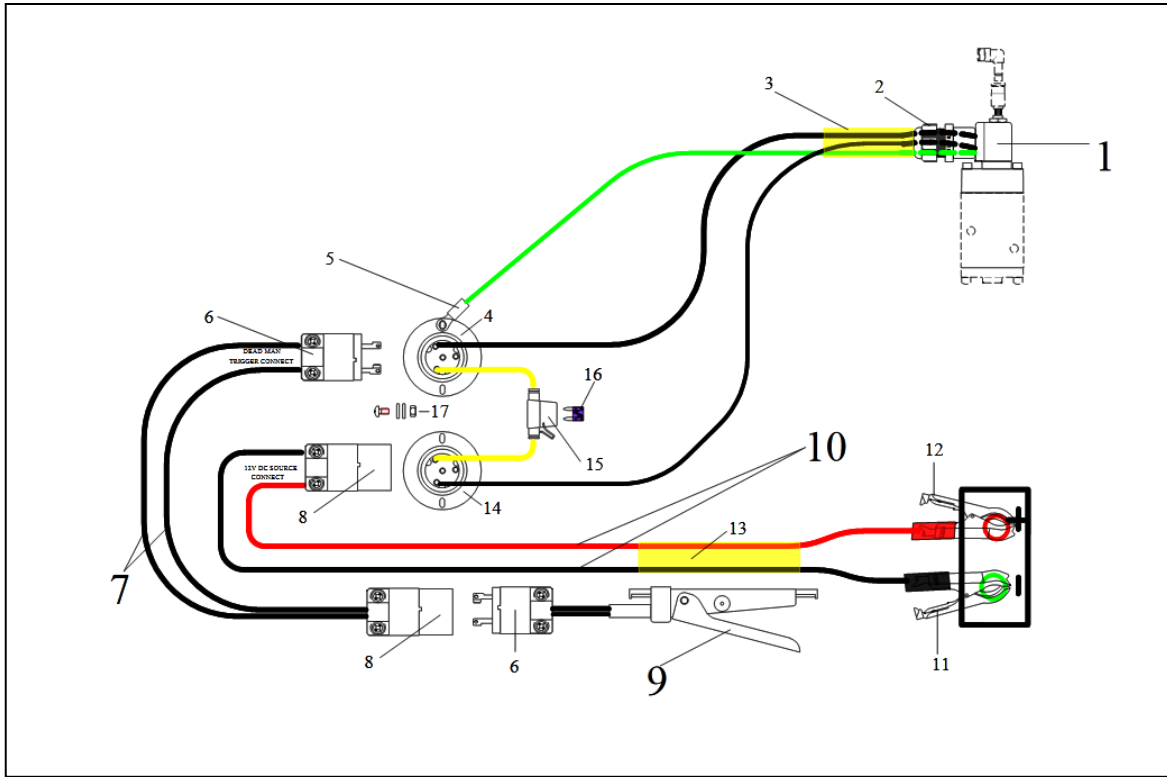

Item	Part Number	Description	Qty	Notes
<b>1</b>	375-33	SOLENOID. 12V DC AIR PILOT ASSEMBLY	AR	
<b>2</b>	4JWN2	CONNECTOR.CORD.STRAIN RELIEF.GRAY. ½ in.	1	Included in #1
<b>3</b>	77676948	TUBING.HEAT SHRINK.YELLOW. ¼ in.	1	12 in. Included in #1
<b>4</b>	62669650	FLANGED INLET. TWIST-LOCK. FEMALE. 2-POLE	1	
<b>5</b>	73125833	TERMINAL.RING.CRIMP-ON.INSULATED. #6 X 16-GAGE	1	Included on #1
<b>6</b>	62670062	PLUG. TWIST-LOCK. MALE. 2-POLE	1	Included on #7
<b>7</b>	DMAE-50	CORD. ELECTRIC. DEADMAN. 52-FT	1	Includes 6 & 8
<b>7 opt</b>	DMAE-100	CORD. ELECTRIC. DEADMAN. 102-FT	AR	Includes 6 & 8
<b>8</b>	62669874	CONNECTOR. TWIST-LOCK. FEMALE. 2-POLE	1	Included in #7 and #10
<b>9</b>	ASSY.2263.02	DEADMAN ELECTRIC HANDLE	1	Includes #6
<b>10</b>	DMA-BC-25	CORD. ELECTRIC. DEADMAN. BATTERY. 25-FT	1	Includes 8,11,12
<b>11</b>	1XWN9	CLAMPS. BATTERY. 50-AMP		Set. Included in #10
<b>12</b>	1XWN9	CLAMPS. BATTERY. 50-AMP		Set. Included in #10
<b>13</b>	77677441	TUBING.HEAT SHRINK.YELLOW. 3/8 in. I.D.	1	6 in. Included in #10
<b>14</b>	62669536	FLANGED INLET. TWIST-LOCK. MALE. 2-POLE	1	
<b>15</b>	E-FH-ATM	FUSE HOLDER. ATM TYPE.	1	
<b>16</b>	E-ATM3	FUSE. ATM BLADE TYPE. 3-AMP	1	
<b>17</b>	Set 10-32	HARDWARE. SCREW.WASHER. NYLON	4	See Page 45

# Water Selector Valve, Dose Valves and Components

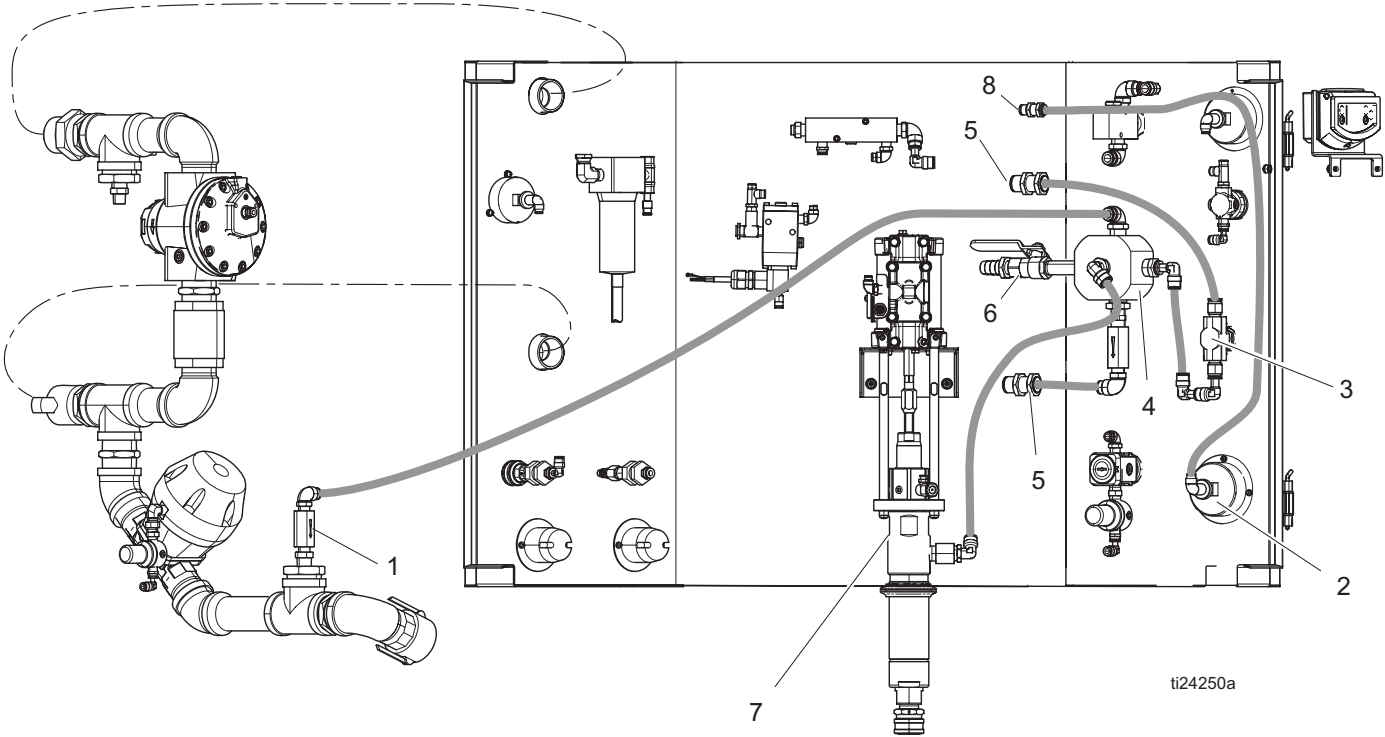

**Components:**

Item	Description	Qty.	Notes
1	Wash Down Check Valve Assembly	1	See Page 57
2	Pot Pressure Gauge Assembly	1	See Page 58
3	Abrasive Metering Valve Assembly	1	See Page 59
4	Selector Valve Assembly	1	See Page 60
5	Bulkhead Push-to-Connect Fittings	1+2	See Page 61
6	Ball Valve 3/8 in. Full Port	1	See Page 62
7	Water Pump Assembly 24V518	1	
8	Bulkhead fitting 125420, M14 x 1/4 in. tube	1	

Water Circuit Sub-assemblies: 1

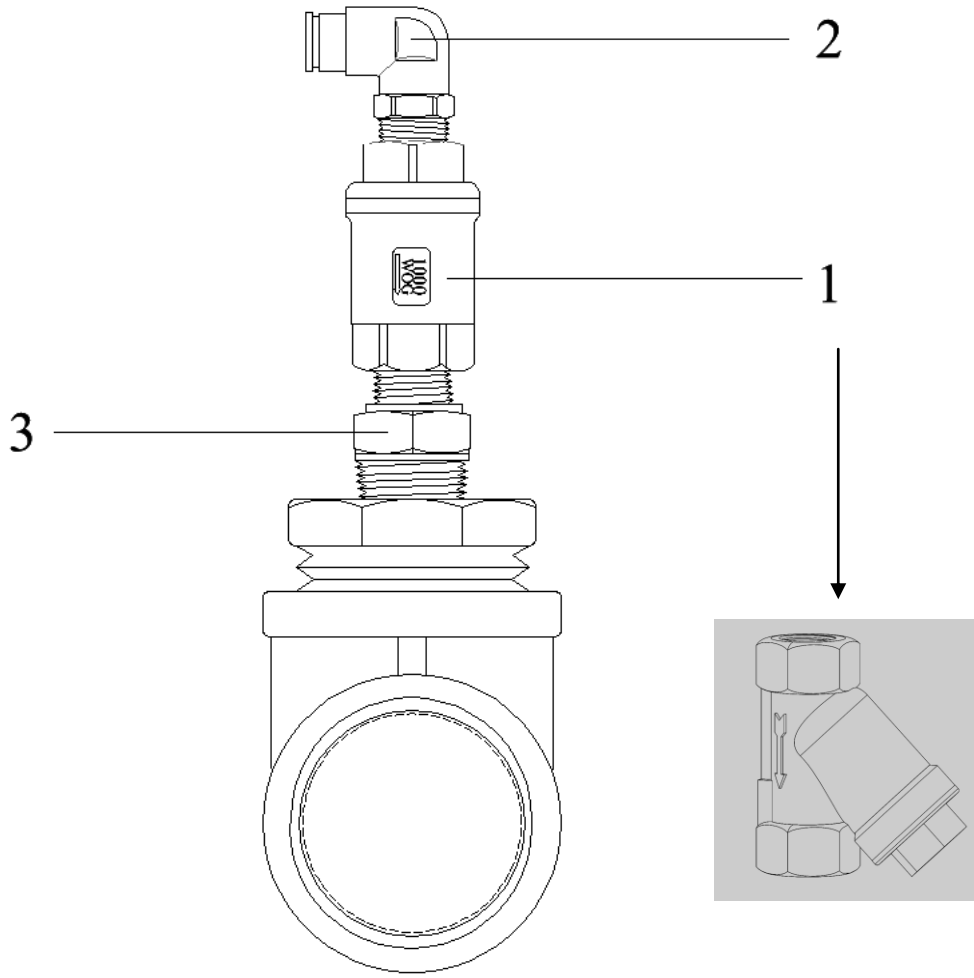

**EQ5139**

Item	Part Number	Description	Qty
1	EQ1034	VALVE, check	1
2	EQ1500	FITTING, elbow, swivel, male, 3/8 in.	1
3	123724	FITTING, nipple, hex, ½ npt x 3/8 npt	1

Water Circuit Sub-assemblies: 2

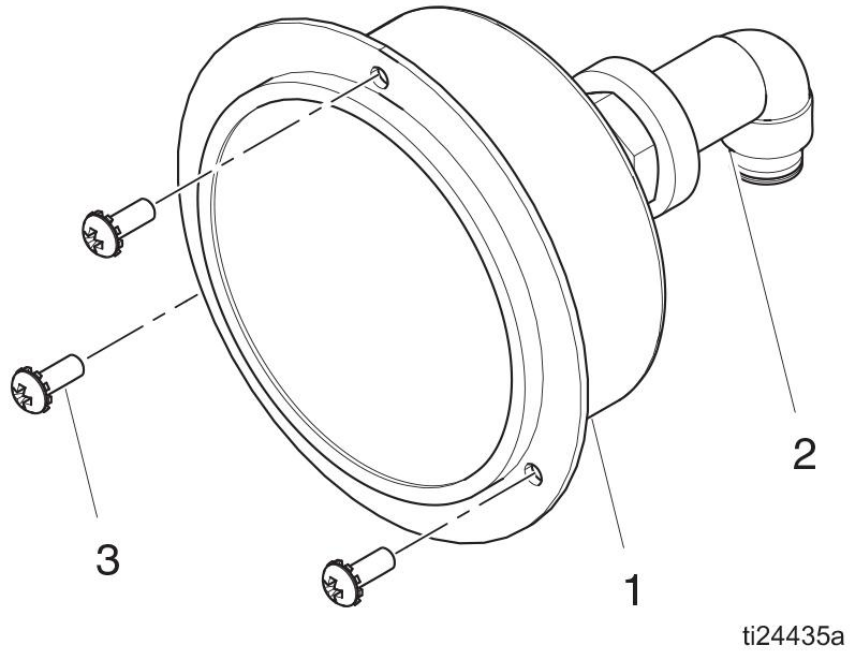

**EQ5107**

ITEM	PART NUMBER	DESCRIPTION	QTY
1	EQ1132	GAUGE, flange mount, 2-1/2 in.	1
2	EQ1113	FITTING, elbow, swivel, female	1
3	127929	SCREW	3

Water Circuit Sub-assemblies: 3  
Needle Valve

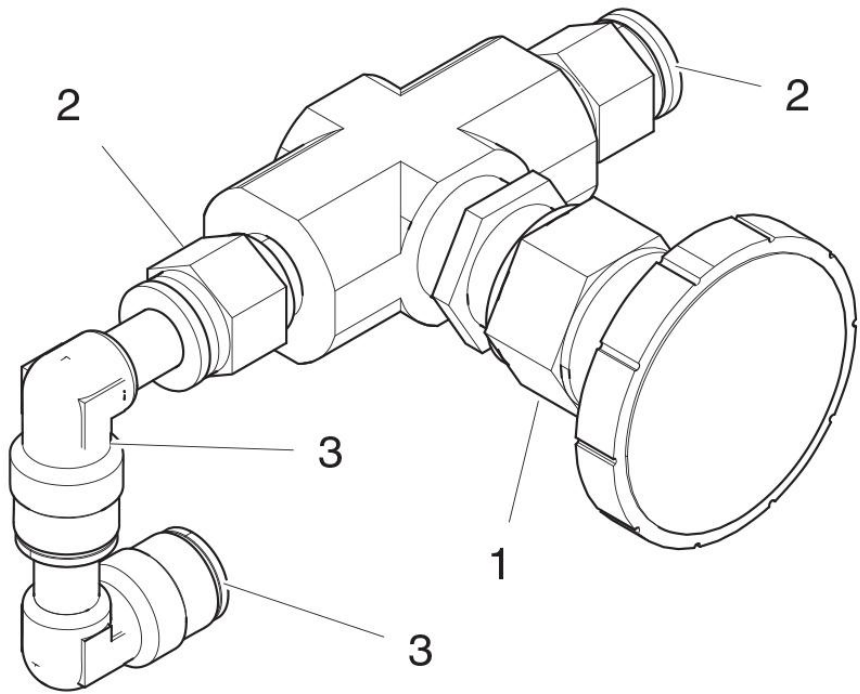

ti24440a

**EQ5160**

ITEM	PART NUMBER	DESCRIPTION	QTY
1	EQ1398	VALVE, needle, dose, integral	1
2	121140	FITTING, straight, 3/8 x 1/4 mnpt	2
3	EQ1122	FITTING, elbow, stem, 3/8	2

Water Circuit Sub-assemblies: 4  
5-Way Selector Valve

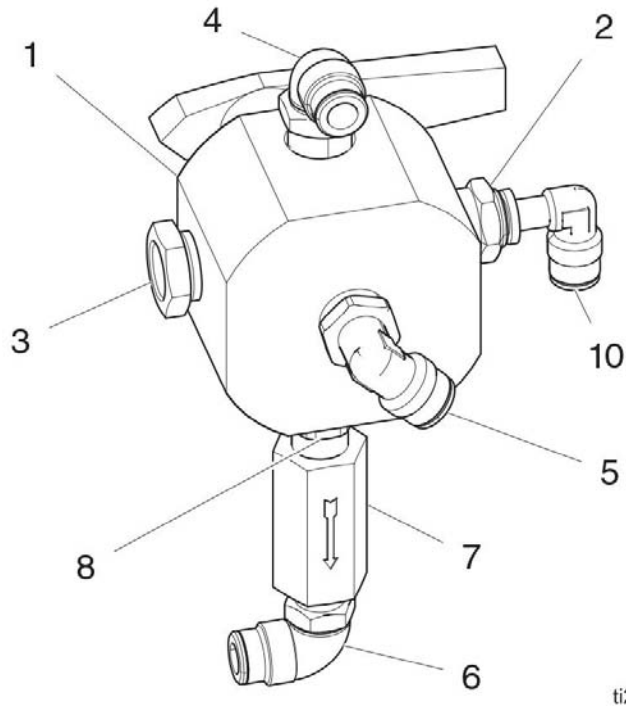

ti24441a

**EQ5181**

ITEM	PART NUMBER	DESCRIPTION	QTY
1	EQ1402	VALVE, ball, switching, ½ in.	1
2	16G247	FITTING, ½ npt x 3/8 tube	1
3	504285	BUSHING, pipe, sst	2
4	EQ1798	FITTING, elbow, swivel, male, 3/8 in.	1
5	127846	FITTING, elbow, push-to-connect, ½ in.	1
6	EQ1500	FITTING, elbow, swivel, male, 3/8 in.	1
7	114243	VALVE, check	1
8	166469	NIPPLE, pipe hex	1
10	EQ1122	FITTING, elbow, stem, 3/8 in.	1

Water Circuit Sub-assemblies: 5

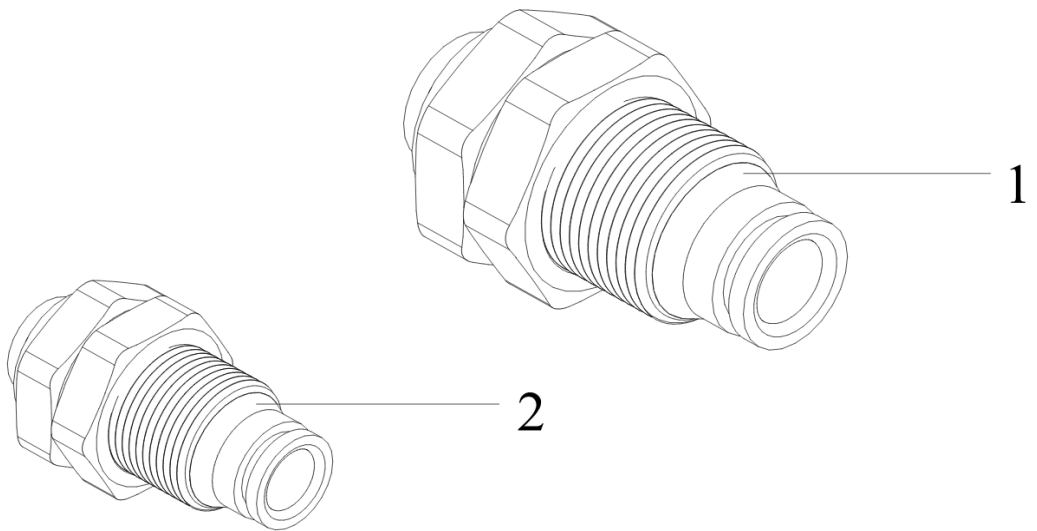

ITEM	PART NUMBER	DESCRIPTION	QTY
1	EQ1115	BULKHEAD, connector, union, 3/8 in.	2
2	125420	FITTING, bulkhead, M14 x 1/4 in. tube	1

Water Circuit Sub-assemblies: 6

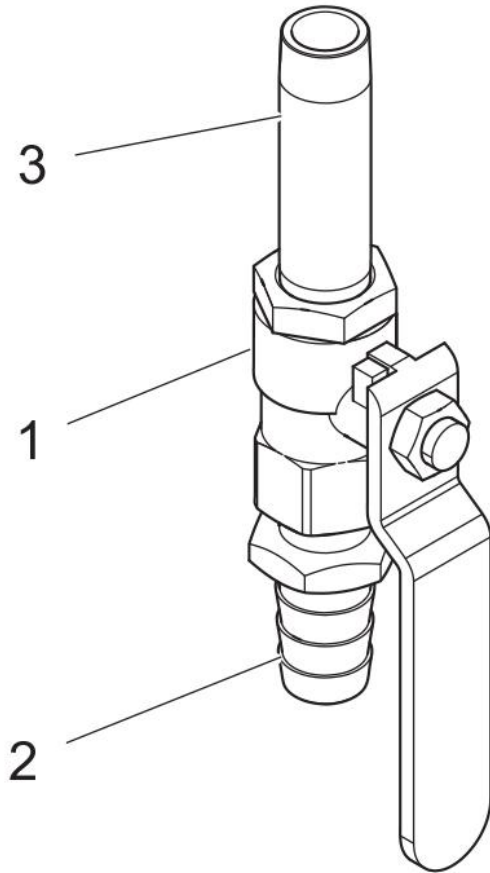

ti24451a

**EQ5125**

ITEM	PART NUMBER	DESCRIPTION	QTY
1	EQ1002	VALVE, ball, full port, 3/8 fpt	1
2	EQ1627	FITING, nipple, barb, hose, 3/8 in.	1
4	EQ1972	FITTING, nipple, ss, 3/8 in. x 2-1/2 in.	1

## Pot Components

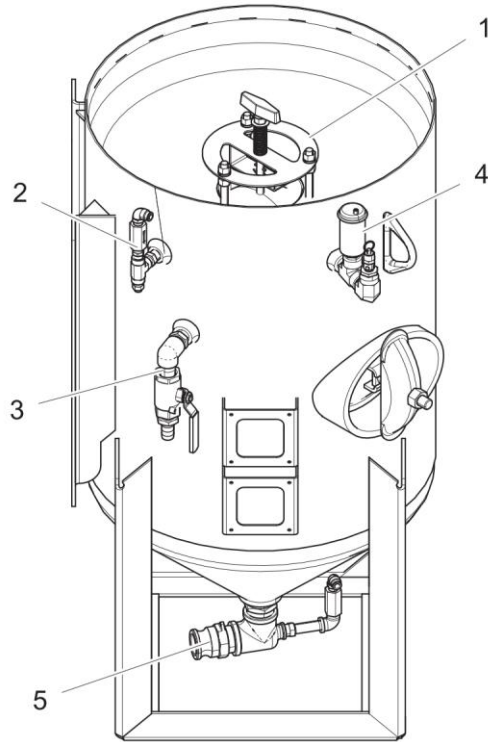

ti24375a

ITEM	PART NUMBER	DESCRIPTION	QTY	NOTES
1		POP-UP ASSEMBLY		SEE PAGE 64
2	ASSY.VCS1-038FILL	CHECK VALVE. POT. FILL PORT	1	SEE PAGE 65
3	ASSY.VBS02-075-DV	VALVE. DUMP. 3/4 in.	1	SEE PAGE 66
4	EQ5134	AUTO-VENT AND RELIEF VALVE ASSY	1	SEE PAGE 66
5	ASSY.1-1/2.951491	UNEQUAL TEE ASSY [EQ600S]	1	SEE PAGE 67
	ASSY.951491	UNEQUAL TEE ASSY W316 HEX [EQ300S]	1	SEE PAGE 68

## Pot Components Pop-Up Components

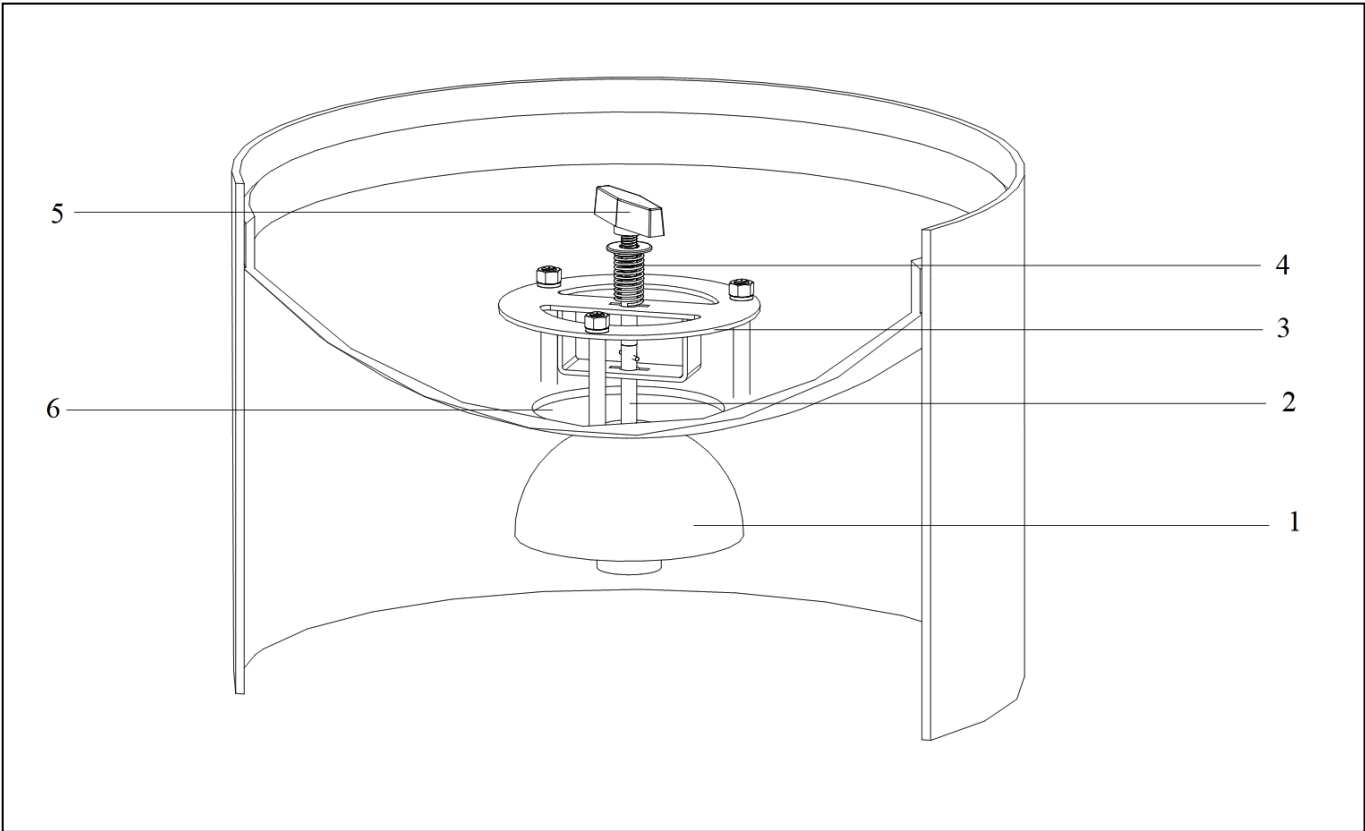

Item #	Part Number	Description	Qty	Notes
1	2100-006-03	HEAD. POP-UP. 6 in. DIA WITH STEM TAPPED 1/2-13 UNC	1	
2	8400-140-06	ROD. THREADED. POP-UP. 1/2-13 X 9-IN LONG WITH 1/8 in. X 1 in. LG DOWEL PIN	1	
3	8400-140-18	BRACKET. POP-UP. ALIGNMENT. TOP HAT FOR 6-IN OPENING	1	
4	8400-140-04	SPRING. COMPRESSION. POP-UP. 7/8 in. OD X 3 in. LONG	1	
5	8400-140-01	HANDLE. T.	1	
6	2100-007	GASKET. POP-UP. 6 in. SKIRT	1	

Pot Components  
Fill Check Valve

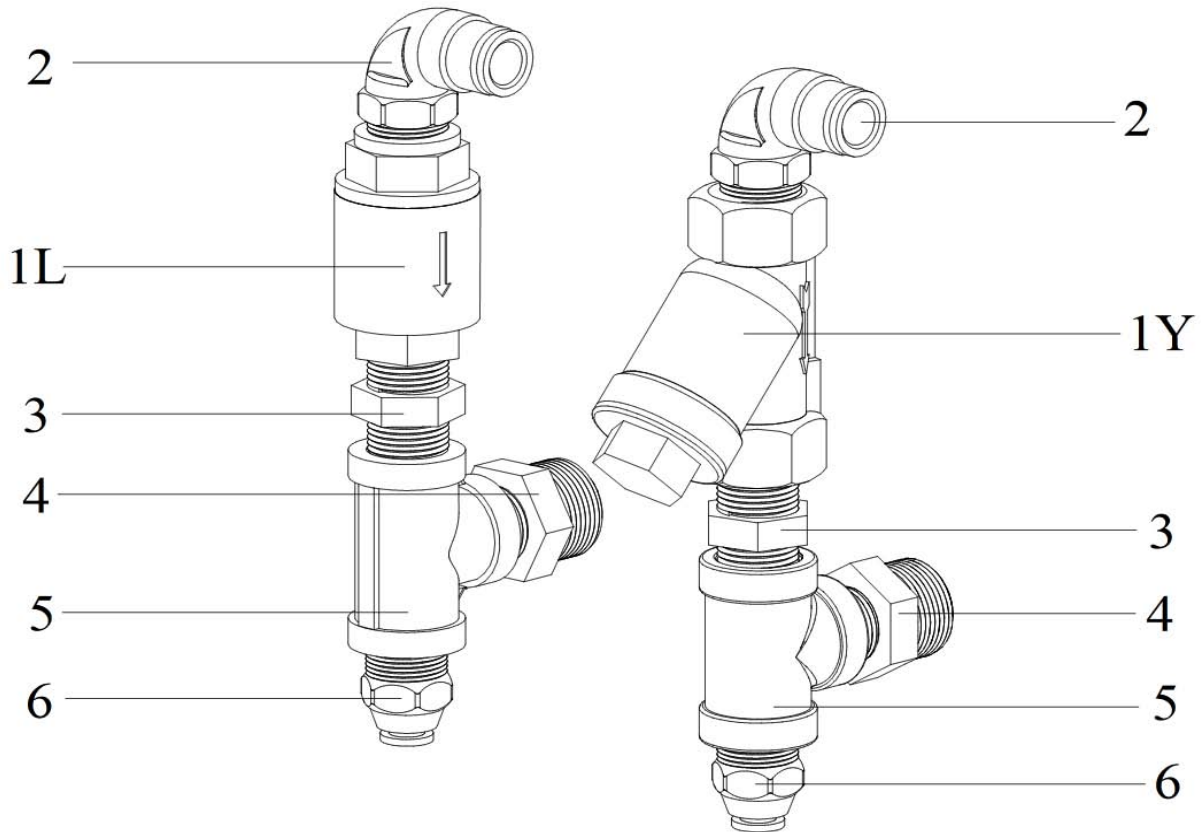

**55132**

Item #	Part Number	Description	Qty	Notes
	<b>ASSY.VCS1-038FILL</b>	CHECK VALVE. POT. FILL PORT		
1Y	VCSY1-038	VALVE. CHECK. Y. SS316. 3/8 in. FPT	AR	Interchangeable
1L	VCSL-038	VALVE. CHECK. IN-LINE. SS316. 3/8 in. FPT	AR	Interchangeable
2	48789366	ELBOW. SWIVEL. MALE. 3/8 in. x 3/8 in.	1	
3	PFT.NH.038	NIPPLE.HEX.NPT.SS. 3/8 in.	1	
4	PFT.NHR.050X038	NIPPLE.HEX.REDUCER.NPT.SS. ½ in. x 3/8 in.	1	
5	PFT-TEE-038	TEE.FPT.SS. 3/8 in.	1	
6	48786669	CONNECTOR.STRAIGHTMALE. ¼ in. x 3/8 in.	1	



## Abrasive Hose & Pot Connections EQ600S

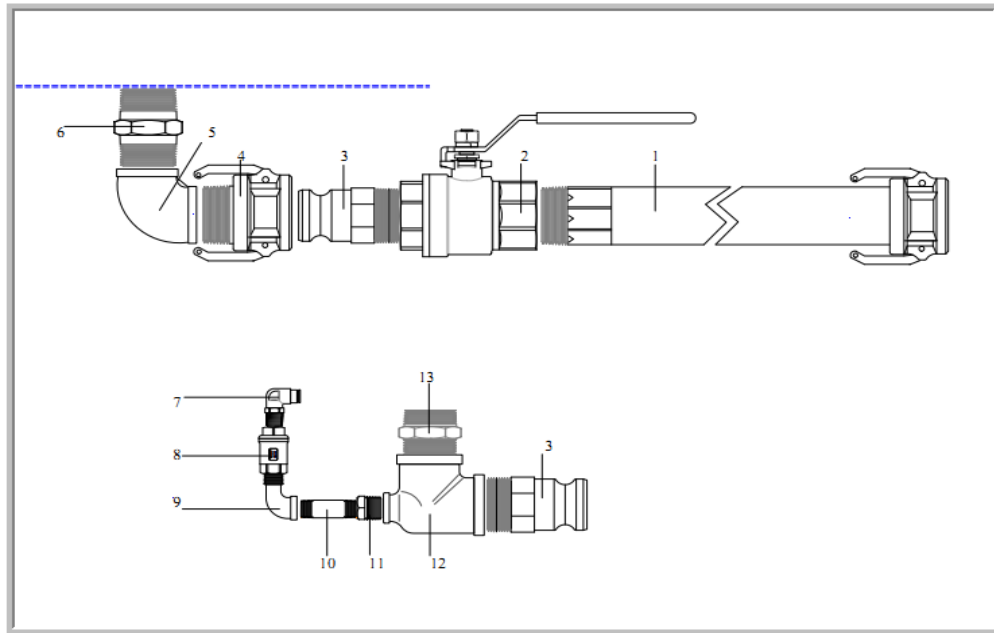

ITEM	PART NUMBER	DESCRIPTION	QTY	NOTES
1	ASSY.1-1/2 in. x 44 in. CX1-1/2 in. MPT	ABRASIVE MEDIA HOSE ASSY FOR EQ600	1	
2	VBS02-150	VALVE. BALL. FULL PORT. 1-1/2 in. FPT SS	1	
3	150-F-SS	CAM.GROOVE.TYPE F.SS. 1-1/2 in. MPT	1	
4	150-D-SS	CAM.LOCK.TYPE D.SS. 1-1/2 in. FPT	1	See Page 40
5	PFT.EL.90°.125	ELBOW.90°.NPT.SS. 1-1/4 in.	1	See Page 40
6	PFT.NH.150	NIPPLE.HEX.NPT.SS. 1-1/2 in.	1	See Page 40
7	48789366	ELBOW. SWIVEL. MALE. 3/8 in. x 3/8 in.	1	
8	VCSL1-038	VALVE. CHECK. IN-LINE. SS316. 3/8 in. FPT	1	
9	PFT.EL.ST.038	ELBOW.STREET.SS. 3/8 in.	1	
10	27-402-1/2	NIPPLE. SS. 3/8 in. x 2-1/2 in.	1	
11	PFT-HRB-050X038	BUSHING.HEX.REDUCER.NPT.SS. ½ in. MPT x 3/8 in.	1	
12	951491	TEE. BRASS. 1-1/2 in. x ½ in. x 1-1/2 in.	1	
13	PFT.NH.150	NIPPLE.HEX.NPT.SS. 1-1/2 in.	1	

## Abrasive Hose & Pot Connections EQ300S

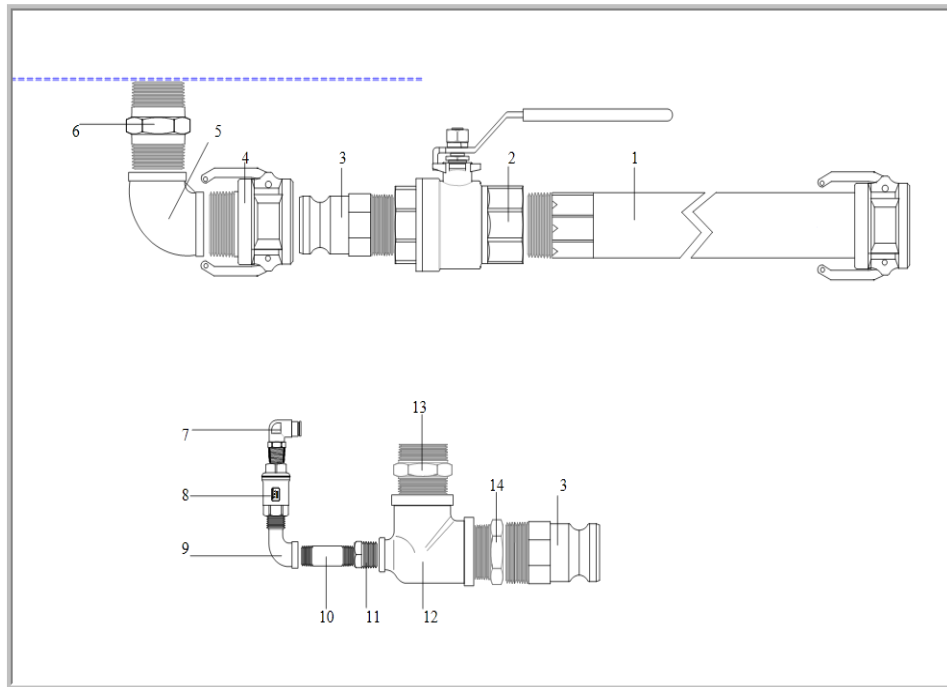

ITEM	PART NUMBER	DESCRIPTION	QTY	NOTES
1	T604- 20 X 44 in. 125CX1, ¼ in. MPT	HOSE, abrasive, blast pot to control panel 1-1/4 in. x 45 in. OAL	1	
2	VBS02-125	VALVE, ball, full port, 1-1/4 in. FPT SS	1	
3	125-F-SS	CAM, groove, type F, ss, 1-1/4 in. MPT	1	
4	125-D-SS	CAM, lock, type D, ss, 1-1/4 FPT	1	See page 40
5	PFT.EL.90°.125	ELBOW, 90°, NPT, ss, 1-1/4 in.	1	See Page 40
6	PFT.NH.125	NIPPLE, hex, NPT, ss, 1-1/4 in.	1	See Page 40
7	48789366	ELBOW, swivel, male, 3/8 in. x 3/8 in.	1	
8	VCSL1-038	VALVE, check, in-line, SS316, 3/8 in. FPT	1	
9	PFT.EL.ST.038	ELBOW, street, 90°, NPT, SS, 3/8 in.	1	
10	27-402	NIPPLE, SS. 3/8 in. x 2-1/2 in.	1	
11	PFT-HRB-050X038	BUSHING, hex, reducer, npt, SS, ½ in. MPT x 3/8 in.		
12	951491	TEE, brass, 1-1/2 in. x ½ in. x 1-1/2 in.	1	
13	PFT.NH.150	NIPPLE, hex, NPT, SS, 1-1/2 in.	1	
14	PFT-HRB-150X050	BUSHING, hex reducer, npt, SS, 1-1/5 in. x ½ in.	1	

# Water Tank and Components

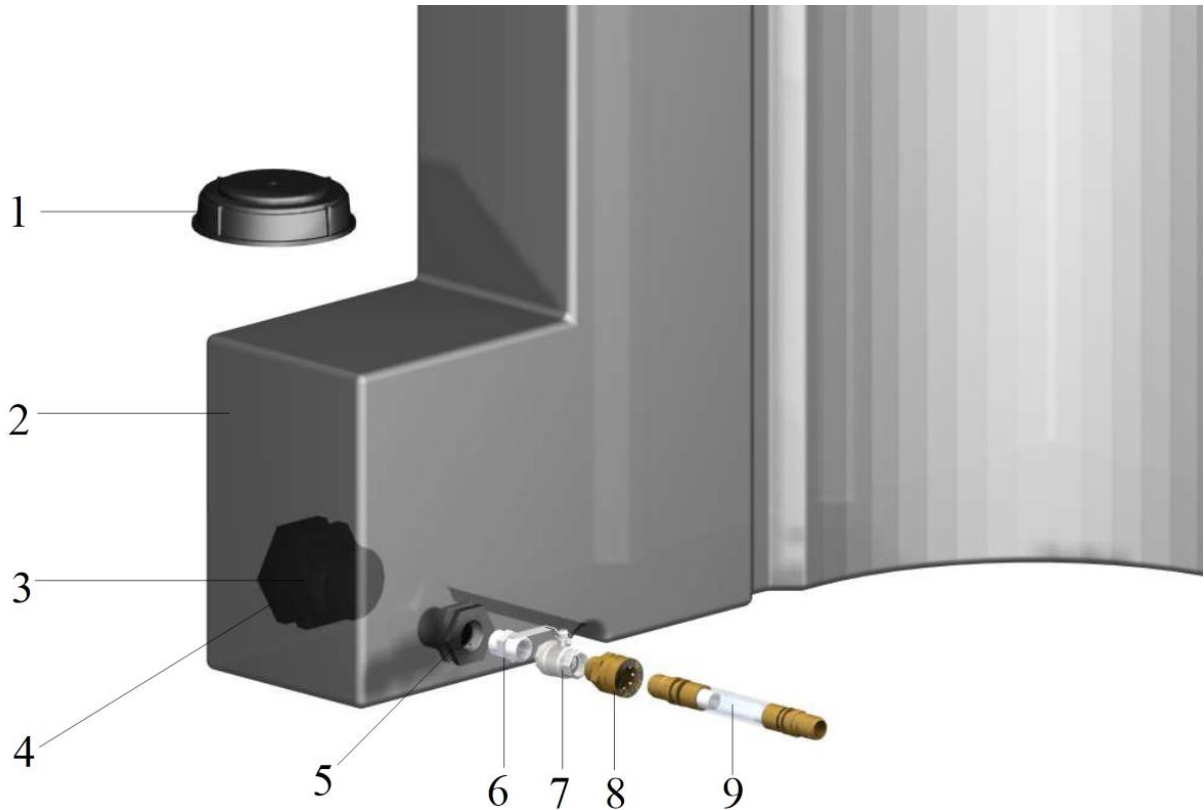

ITEM	PART NUMBER	DESCRIPTION	QTY	NOTES
1	LID-05 – 5 in.	THREADED VENTED TANK LID	1	
2	ECO-L-TANK	TANK. WATER. L-SHAPED. 125-GAL	1	
3	63274088	PLUG. DRAIN. WASTE. 2 in.	1	
4	567002	FITTING. BULKHEAD. W/EPDM 2 in. FPT	1	
5	37003753	FITTING. PIPE. COUPLING. BH TNK ADPT. ¾ in. SCH 80 CPVC	1	
6	PFT.NH.075	NIPPLE.HEX.NPT.SS. ¾ in.	1	
7	VBS02-075	VALVE.BALL.FULL PORT.NPT.SS. ¾ in. FPT	1	
8	6EM6-B	COUPLER. INTERCHANGE. STRAIGHT-THRU ¾ in. MPT	1	
9	17C032	HOSE.INLET.WATER	1	

# Technical Specifications

<b>EQ300S</b>		
	<b>U.S.</b>	<b>Metric</b>
Maximum Working Pressure	125 psi	8.6 Bar, 0.86 MPa
Operating Temperature	35° - 110° F	1.6° - 43.3° C
Air Consumption	165 - 375 cfm	m <sup>3</sup> /min
Abrasive Consumption	1 - 2 lb / hour	0.45 - 0.9 kg / hour
Blast Hose Size	1 in. ID	1 in. ID
Abrasive Capacity	400 - 500 lb	181 - 227 kg
Dry Weight	1100 lb	499 kg
Wet Weight	2900 lb	1315 kg
<b>*Sound Data:</b>		
Sound Pressure Level	133 dB(A)	133 dB(A)
Sound Power Level	139 dB(A)	139 dB(A)
Instantaneous Sound Pressure Level	131 dB(C)	131 dB(C)
<i>*All readings were taken at max system blast pressure 125 psi (8.6 bar, 0.86 MPa) from the operator position. The media used was garnet and the substrate was steel. Tested in accordance with ISO 9614-2</i>		

<b>EQ600S</b>		
	<b>U.S.</b>	<b>Metric</b>
Maximum Working Pressure	125 psi	8.6 Bar, 0.86 MPa
Operating Temperature	35° - 110° F	1.6° - 43.3° C
Air Consumption	375 - 600 cfm	m <sup>3</sup> /min
Abrasive Consumption	1 - 2 lb / hour	0.45 - 0.9 kg / hour
Blast Hose Size	1 in. ID	1 in. ID
Abrasive Capacity	400 - 500 lb	181 - 227 kg
Dry Weight	1100 lb	499 kg
Wet Weight	2900 lb	1315 kg
<b>*Sound Data:</b>		
Sound Pressure Level	133 dB(A)	133 dB(A)
Sound Power Level	139 dB(A)	139 dB(A)
Instantaneous Sound Pressure Level	131 dB(C)	131 dB(C)
<i>*All readings were taken at max system blast pressure 125 psi (8.6 bar, 0.86 MPa) from the operator position. The media used was garnet and the substrate was steel. Tested in accordance with ISO 9614-2</i>		

# Notes

# Graco Standard Warranty

Graco warrants all equipment referenced in this document which is manufactured by Graco and bearing the Graco or EcoQuip name to be free from defects in material and workmanship on the date of sale to the original purchaser for use. Graco will, for three (3) years from the date of sale, repair or replace any part of the equipment determined by Graco to be defective. This warranty applies only when the equipment is installed, operated and maintained in accordance with Graco's written recommendations.

This warranty does not cover, and Graco shall not be liable for general wear and tear, or any malfunction, damage or wear caused by faulty installation, misapplication, abrasion, corrosion, inadequate or improper maintenance, negligence, accident, tampering, or substitution of non-Graco component parts. Nor shall Graco be liable for malfunction, damage or wear caused by the incompatibility of Graco equipment with structures, accessories, equipment or materials not supplied by Graco, or the improper design, manufacture, installation, operation or maintenance of structures, accessories, equipment or materials not supplied by Graco.

This warranty is conditioned upon the prepaid return of the equipment claimed to be defective to an authorized Graco distributor for verification of the claimed defect. If the claimed defect is verified, Graco will repair or replace free of charge any defective parts. The equipment will be returned to the original purchaser transportation prepaid. If inspection of the equipment does not disclose any defect in material or workmanship, repairs will be made at a reasonable charge, which charges may include the costs of parts, labor, and transportation.

THIS WARRANTY IS EXCLUSIVE, AND IS IN LIEU OF ANY OTHER WARRANTIES, EXPRESS OR IMPLIED, INCLUDING BUT NOT LIMITED TO WARRANTY OF MERCHANTABILITY OR WARRANTY OF FITNESS FOR A PARTICULAR PURPOSE.

Graco's sole obligation and buyer's sole remedy for any breach of warranty shall be as set forth above. The buyer agrees that no other remedy (including, but not limited to, incidental or consequential damages for lost profits, lost sales, injury to person or property, or any other incidental or consequential loss) shall be available. Any action for breach of warranty hereunder must be brought within the latter of two (2) years of the date of sale, or one (1) year after the warranty period expires.

GRACO MAKES NO WARRANTY, AND DISCLAIMS ALL IMPLIED WARRANTIES OF MERCHANTABILITY AND FITNESS FOR A PARTICULAR PURPOSE, IN CONNECTION WITH ACCESSORIES, EQUIPMENT, MATERIALS OR COMPONENTS SOLD BUT NOT MANUFACTURED BY GRACO. These items sold, but not manufactured by Graco (such as electric motors, switches, compressors, engines, trailer components, blast hose or other hose and blast nozzles), are subject to the warranty, if any, of their manufacturer. Graco will provide purchaser with reasonable assistance in making any claim for breach of these warranties.

In no event will Graco be liable for indirect, incidental, special or consequential damages resulting from Graco supplying equipment hereunder, or the furnishing, performance, or use of any products or other goods sold hereto, whether due to a breach of contract, breach of warranty, the negligence of Graco, or otherwise.

## FOR GRACO CANADA CUSTOMERS

The Parties acknowledge that they have required that the present document, as well as all documents, notices and legal proceedings entered into, given or instituted pursuant hereto or relating directly or indirectly hereto, be drawn up in English. Les parties reconnaissent avoir convenu que la rédaction du présente document sera en Anglais, ainsi que tous documents, avis et procédures judiciaires exécutés, donnés ou intentés, à la suite de ou en rapport, directement ou indirectement, avec les procédures concernées.

## Graco Information

For the latest information about Graco products, visit [www.graco.com](http://www.graco.com).

For patent information, see [www.graco.com/patents](http://www.graco.com/patents).

**TO PLACE AN ORDER**, contact your Graco distributor or call to identify the nearest distributor.

**Phone:** 612-623-6921 **or Toll Free:** 1-800-328-0211 **Fax:** 612-378-3505.

*All written and visual data contained in this document reflects the latest product information available at the time of publication. Graco reserves the right to make changes at any time without notice.*

Original instructions. This manual contains English. MM 334143

**Graco Headquarters:** Minneapolis

**International Offices:** Belgium, China, Japan, Korea

**GRACO INC. AND SUBSIDIARIES • P.O. BOX 1441 • MINNEAPOLIS MN 55440-1441 • USA**

**Copyright 2014, Graco Inc. All Graco manufacturing locations are registered to ISO 9001.**

[www.graco.com](http://www.graco.com)

Revision A - August 2014